

Sensor mounting

The optoNCDT ILR3800 sensors are optical sensors that operate with millimeter accuracy.

i Ensure careful handling during installation and operation!

➤ Mount the sensor only using the provided through-holes on a level surface. Any type of clamping is not permitted.

➤ Alternatively, mount the sensor to the mounting plate (optional accessory) using two M4 screws via the through holes. This plate offers a variety of tilting options.

The sensor can be raised or lowered at the front and rear using four set screws to adjust the position of the laser beam.

Through-bolt connection				
Through-bolt length	Screw-in depth	Number	Screw	Torque
6.5 mm	Min. 10 mm	4	M4 ISO 4762-A2	1.7 N·m for strength class 70 2.3 N·m for strength class 80

Term definitions, analog output for displacement

The measuring range of the ILR3800 starts in front of the sensor. The point of reference is the front housing edge on the sensor housing.

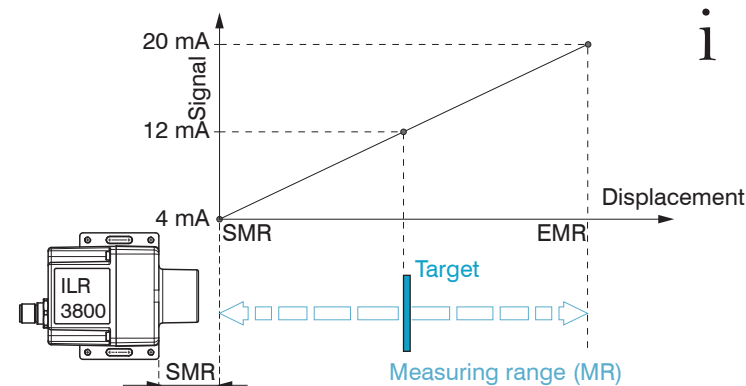

i Position the sensor so that the connections and LED elements are not concealed.

- SMR Start of measuring range, minimum distance between sensor and target
- EMR End of measuring range (start of measuring range + measuring range), maximum distance between sensor and target
- MR Measuring range

Unpacking, included in delivery

- 1 sensor ILR3800-100-IO
- 1 assembly screw set
- 1 setup guide

Sensor mounting, dimensional drawing

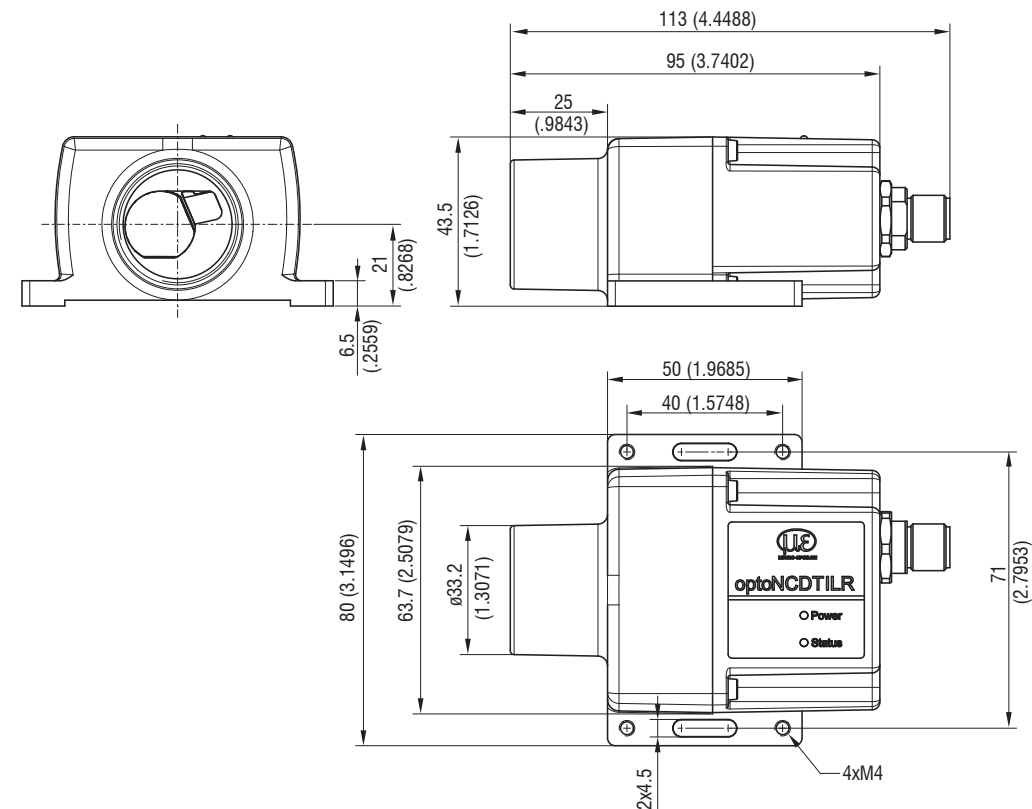

Dimensional drawing optoNCDT ILR3800-100 IO, dimensions in mm

Aligning sensor / reflector

The sensor measures the distance to moving and stationary objects:

- In a range from 0.05 m ... 100 m on diffusely reflecting surfaces
- Between 35 and 150 m onto reflectors (e.g. ILR-RF210, Scotchlight by 3M etc.)

The measurement laser can be used for alignment. When aligning the sensor, proceed as follows:

- When measuring on reflectors or shiny surfaces, keep a distance of at least 35 m to avoid damage to sensor components caused by the reflected light. The visible point of light of the measurement laser should be in the center of the reflector.
- Position the sensor at least 35 m away from the reflector.
- Check that the measurement laser is pointing at the center of the reflector and adjust if necessary.

The laser spot must be in the center of the reflector over the entire measuring range. Target (reflector) and sensor can only be tilted by at most 5° relative to one another.



Setup Guide optoNCDT ILR3800-100-IO

Intended use

The optoNCDT ILR3800 measuring system is designed for industrial and laboratory applications. It is used for displacement, distance and position measurements. The system must only be operated within the limits specified in the technical data, see Operating Instructions, Chap 3.4.

The system must be used in such a way that no persons are endangered or machines and other material goods are damaged in the event of malfunction or total failure of the system. Take additional precautions for safety and damage prevention in case of safety-related applications.

Warnings

Risk of injury, damage to or destruction of the sensor

- Connect the power supply according to the safety regulations for electrical equipment. The supply voltage must not exceed the specified limits.
- Mount the sensor only using the provided through-holes on a level surface. Any type of clamping is not permitted.

Damage to or destruction of the sensor, failure of measuring device

- Avoid shocks and impacts to the sensor, and protect the sensor cable from damage.
- Do not touch the lenses or protective windows. Remove any fingerprints immediately using pure alcohol and a clean cotton cloth without leaving any streaks.
- Do not operate the sensor if optical components are steamed up or dirty.

Laser safety

The optoNCDT ILR3800-100-IO sensors operate with a semiconductor laser with a wavelength of 655 nm (visible/red). The sensors fall within laser class 2. The laser is pulsed; the maximum optical power is ≤ 1 mW. Operation of the laser is indicated visually by the Signal LED on the sensor. The following warning signs are attached to the front of the sensor housing:



Laser warning and laser information sign, optoNCDT ILR 3800-100, IEC

The German laser information sign is enclosed.



Laser radiation. Eyes could become irritated or damaged. Close your eyes, or immediately turn away if the laser beam hits the eye.

Indicator elements, LEDs

LED	Function	Indicator	Status
Status	Reflection strength	Green	Signal very good
		Yellow	Signal satisfactory
		Red	Weak signal/error
Power	Operational readiness	Off	No power supply
		Green	Ready for operation



Supply voltage, nominal value: 24 V DC (10 ... 30 V, P < 4 W)

The ILR3800-100-IO sensor is supplied via the IO-Link master.

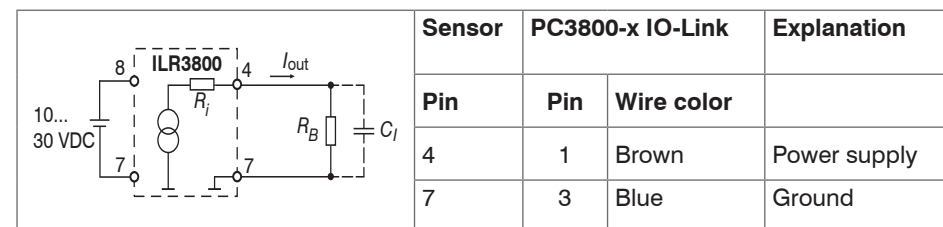

Use the power supply only for measuring devices; do not use it at the same time for drives or similar sources of impulse interference.

Pin assignment

Sensor signal	Explanation	PC3800-x IO-Link	
		Pin	Adernfarbe
+U _B	Supply voltage 10 ... 30 VDC, typ. 24 VDC	1	Brown
C/Q	Standard Input/Output	4	Black
GND	Supply ground	3	Blue

View: Solder side 5-pin M12 cable connector

Schnelleinstieg

Mount the sensor.

The sensor is connected via IO-Link using an IO-Link cable directly from the sensor to the IO-Link master.



The measuring laser starts when power is applied.

The sensor is ready to use after approx. 2 s, digital accuracy is immediate.

The measuring laser is switched on in its factory state. If the sensor is then switched off during an active measurement, it immediately resumes the saved measurement task once the power supply is connected again.

If the POWER LED is off, no power is being supplied.

Operation using IO-Link

The sensor exchanges process data and parameters via IO-Link.

IO-Link specification	V 1.1
Minimum cycle time	4.0 ms (COM2)
Transmission speed	COM2 (38.4 kBaud)
Process data width	32 bit output (from device to master)
Process data type	Mixed (27 bit integer + 3 Boolean)
Parameterization server function (data storage)	Yes

IO-Link interface properties

Proper environment

Protection class: IP65 (applies only when sensor cable is plugged in)

The protection class does not apply to optical entries, as contamination will impair or prevent their function.

- Temperature range:
 - Operation: -10 ... +50 °C
 - Storage: -25 ... +70 °C
- Humidity: 5 ... 95 % RH (nicht kondensierend)
- Ambient pressure: Atmospheric pressure

You can find more information about the sensor in the operating instructions.

They are available online at:

<https://www.micro-epsilon.de/download-file/man--optoNCDT-ILR-3800--en.pdf>



Process data

The factory settings ensure that the process data telegram of the sensor receives the measured distance value. The distance value is output in tenths of a millimeter (27-bit signed integer). In addition, the logical state of the three switching outputs is transmitted by the last three bits.

Bit 0 – Bit 26	Measurement value
Bit 29	ErrorOut3 (switching output 3)
Bit 30	ErrorOut2 (switching output 2)
Bit 31	ErrorOut1 (switching output 1)

Factory-set process data format

Device data

The device data include

- parameters,
- identification data and
- diagnosis data.

This information can be transmitted to or from the sensor in parallel with the process data. For this purpose, the IO-Link master requires a sensor-specific device description file (IODD).

The current device description file is available at:

<https://www.micro-epsilon.com/distance-sensors/laser-distance-sensors/optoncdt-ilr3800/?sLang=en>

Laser spot diameter, min. target size

The laser spot diameter increases with increasing distance (displacement). Keep this in mind for the selection/size of the target.

The measuring object must have at least three times the size of the laser spot.

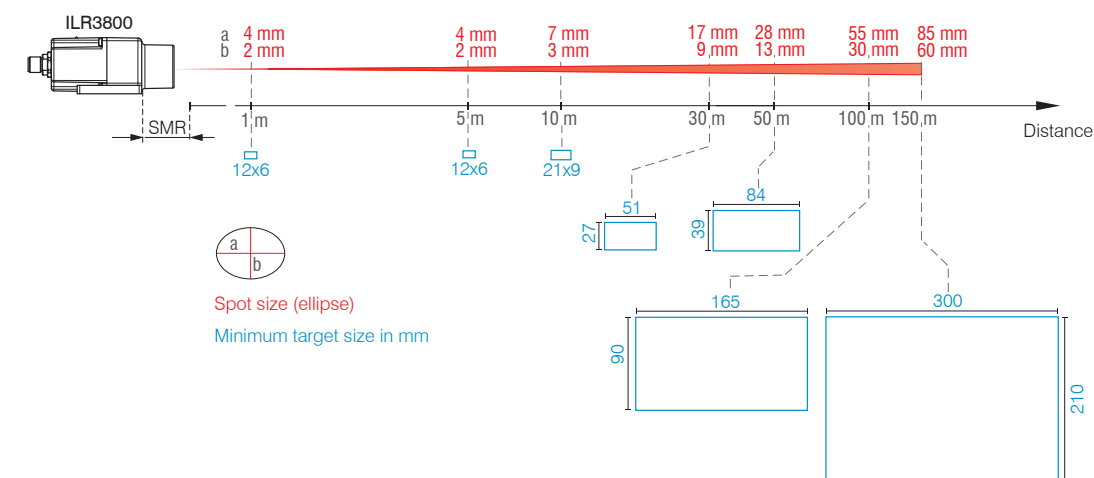

Laser spot dimensions and size of measuring object depending on the distance

MICRO-EPSILON Eltrotec GmbH
 Manfred-Wörner-Straße 101 • 73037 Göppingen / Deutschland
 Tel. +49 (0)7161 98872-300 • Fax+49 (0)7161 98872-303
 eltrotec@micro-epsilon.de • www.micro-epsilon.de

Your local contact: www.micro-epsilon.com/contact/worldwide/



X9771490.01-A012036TSw