



Quick Manual
confocalDT 2411/2416
Ethernet



IFC2411
IFC2416

Contents

General	3	Initial Operation	12
Symbols Used	3	Access via Web Interface	13
Warnings	3	Positioning the Target	14
Intended Use	4	Presets, Setups, Measurement Configuration, Signal Quality... ..	15
Proper Environment	4	Checking the Video Signal, Peak Selection	17
Glossary	4	Distance Measurement with Website Display	18
Mechanical Fastening	5	One-Sided Thickness Measurement, Transparent Target	20
Sensor	5	Preset Selection	20
Mechanical Fastening Controller	6	Material Selection.....	20
Electrical Connections	7	Layer Thickness Measurement, Transparent Target	21
Supply Voltage	8	Preset Selection	21
Synchronization, Trigger	8	Peak Selection	21
Switching Output (IFC2416 only)	9	Video Signal	22
RS422 Communication	9	Material Selection.....	23
Multifunction Button	10	Measurement Chart for Thickness Measurement	23
Controller LEDs	10	Data Format Ethernet Interface	24
Sensor Cable, Optical Fiber	11	Data Format RS422 Interface	25
		Service, Repair	26
		Disclaimer	26
		Decommissioning, Disposal	27

MICRO-EPSILON
MESSTECHNIK
GmbH & Co. KG
Koenigbacher Str. 15
94496 Ortenburg / Germany

Tel. +49 (0) 8542 / 168-0
Fax +49 (0) 8542 / 168-20
info@micro-epsilon.com
www.micro-epsilon.com

You can find more information about the measuring system
in the operating instructions. They are available online at:

[https://www.micro-epsilon.com/download-file/
man--confocalDT-2411-2416-Ethernet--en.pdf](https://www.micro-epsilon.com/download-file/man--confocalDT-2411-2416-Ethernet--en.pdf)



General

Symbols Used

The following symbols are used in this document:



Indicates a hazardous situation which, if not avoided, may result in minor or moderate injury.



Indicates a situation that may result in property damage if not avoided.



Indicates a user action.



Indicates a tip for users.

Measurement

Indicates hardware or a software button/menu.

Warnings



Connect the power supply and the display/output device according to the safety regulations for electrical equipment.

> Risk of injury, damage to or destruction of the controller

When all interfaces are used, the controller heats up to more than 50 °C.

> Risk of injury



Avoid shocks and impacts to the sensor and controller.

> Damage to or destruction of the sensor and/or controller

The supply voltage must not exceed the specified limits.

> Damage to or destruction of the sensor and/or controller

Protect the cables against damage.

> Failure of the measuring device

Intended Use

- The measuring system is designed for use in an industrial environment. It is used for
 - displacement, distance, movement and thickness measurement,
 - measuring the position of parts or machine components
 - The measuring system must only be operated within the limits specified in the technical data.
- ➔ The measuring system must only be used in such a way that no persons are endangered or machines are damaged in the event of malfunction or total failure of the controller.
- ➔ Take additional precautions for safety and damage prevention in case of safety-related applications.

Proper Environment

	Sensor	Controller
Protection class	IP64, front side	IP40
Operating temperature range	+5 ... +70 °C	+5 ... +50 °C
Temperature range (storage)	-20 ... +70 °C	
Humidity	5 ... 95 % (non-condensing)	
Ambient pressure	Atmospheric pressure	
Shock (DIN-EN 60068-2-27)	15 g / 6 ms in XY-axis, 1000 shocks each	
Vibration (DIN-EN 60068-2-6)	2 g / 20 ... 500 Hz in XY-axis, 10 cycles each	

Glossary

SMR Start of measuring range

MMR Mid of measuring range

MR Measuring range

EMR End of measuring range

Minimum target thickness see Technical Data, Operating Instructions

Maximum target thickness Sensor measuring range x Refractive index of target

Mechanical Fastening

Sensor

The optical sensors operate in the nanometer range. Observe the maximum tilt angle between sensor and target.

- **i** Ensure careful handling during installation and operation!

The dimensional drawings for the IFS240x series sensors, their mounting, and the MA240x series mounting adapters are summarized in a separate document. You can find these online at:

<https://www.micro-epsilon.com/download-file/set--confocalDT-Sensoren--en.pdf>

Fasten the sensors with a circumferential clamp. This type of sensor mounting ensures the highest level of reliability because the sensor's cylindrical housing is clamped over a relatively large area. This is absolutely necessary in difficult installation situations, such as on machines, production lines, etc.



Circumferential clamping with MA2400-27 mounting adapter

Mechanical Fastening Controller

The IFC2411/2416 controller can be mounted, e.g., in a control cabinet using a top-hat rail TH 35 according to DIN EN 60715.

- When attaching the controller, ensure that no connections, operating or display elements are covered. The minimum distance between adjacent controllers is 10 mm.

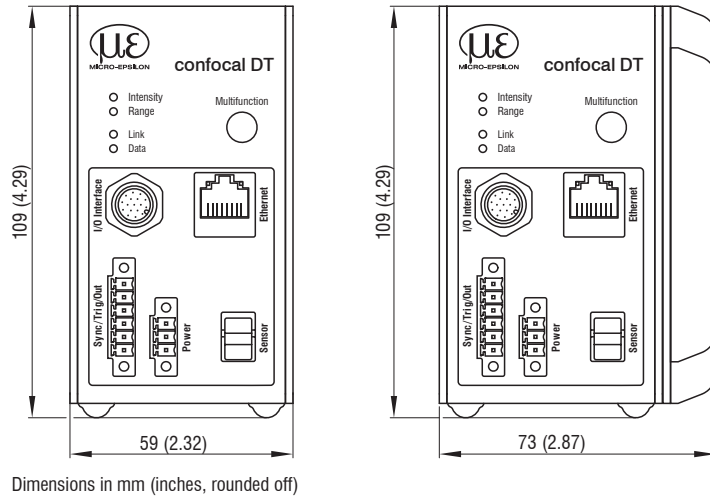

Dimensional drawing IFC2411 (left) / IFC2416, front view

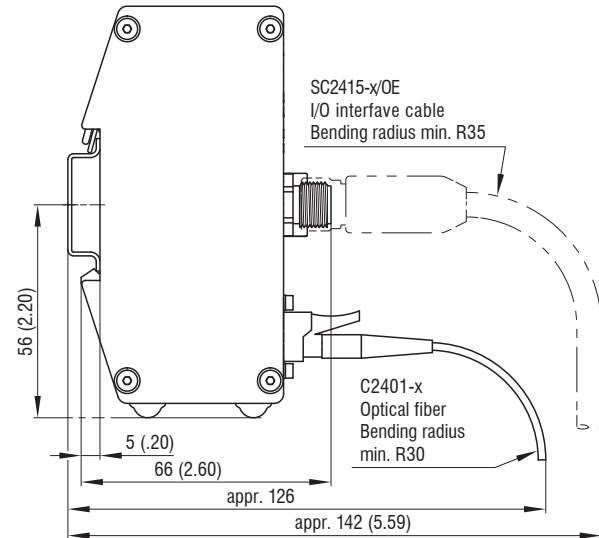

Dimensional drawing IFC2411/2416, side view

Electrical Connections

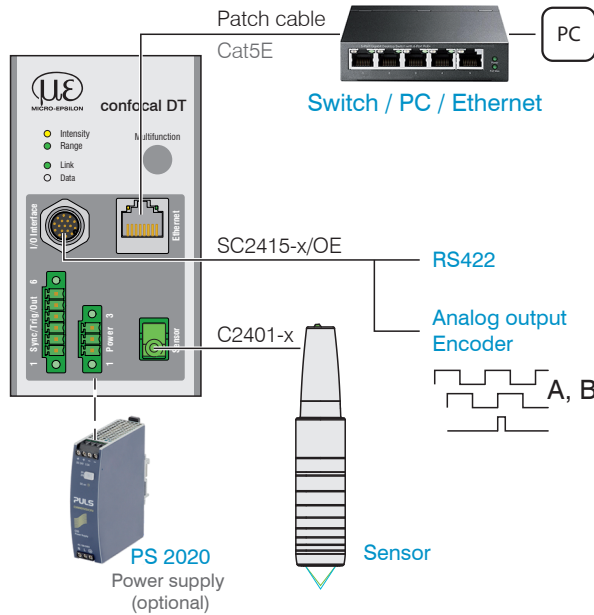

Characteristics SC2415-x/OE signal line:

- Analog output
- RS422
- Encoder

The SC2415-x/OE cable is not included in delivery.

17-pin connector	SC2415-x/OE Wire color	IFC2411	IFC2416	
			Standard	Alternative
1	White ¹		Analog Output	
2	Black ¹		Analog GND	
3	Black	Data Tx -	Data Tx -	Encoder 2B -
5	Red	n.c.	Encoder 2Ref+	Encoder 2Ref+
8	Grey		Encoder 1B+	
9	Green		Encoder 1Ref+	
10	Brown	Data Rx+	Data Rx+	Encoder 2A+
11	White	Data Rx -	Data Rx -	Encoder 2A -
12	Red/Blue		Encoder 1A -	
13	Purple	Data Tx+	Data Tx -	Encoder 2B+
14	Blue	n.c.	Encoder 2Ref -	Encoder 2Ref -
15	Pink		Encoder 1B -	
16	Yellow		Encoder 1Ref -	
17	Grey/Pink		Encoder 1A+	

Pin assignment SC2415-x/OEY

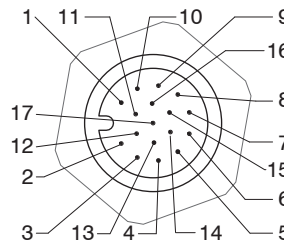

The GND connections are not electrically separated.

17-pin controller male connector, pin side

1) Analog output in shielded cable area

Supply Voltage

Nominal value: 24 V DC (20 ... 28 V)

Power consumption < 7 W (IFC2411), <9 W (IFC2416)

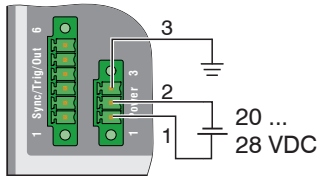

Controller	Power supply
3-pin pluggable screw terminal	
1	V ₊
2	GND
3	Screen

Voltage supply only for measuring devices, not to be used for drives or similar sources of impulse interference at the same time. Micro-Epsilon recommends using an optional available power supply unit PS2020 for the sensor.

- ➡ Only turn on the power supply after wiring has been completed.
- ➡ Connect the inputs Pin 1 and Pin 2 at the sensor with a 24V power supply.

Synchronization, Trigger

- ➡ Interconnected all GND, if the controllers are not supplied from a common power supply.

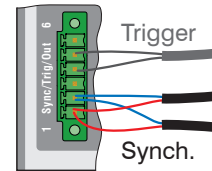

Controller	Signal	Level
5-pol pluggable screw terminal		
1	Sync +	RS422
2	Sync -	RS422
3	Cable shield	
4	Trig	TTL
5	GND	

Star- or Cascaded synchronization

- ➡ Connect Pins 1 and 2 of controller 1 (master) with the correct polarity to Pins 1 and 2 of controller 2 (slave) to controller n, in order to synchronize two or more controllers.

Triggering

- ➡ Connect the pins 4 and 5 with a trigger source (master).

Switching Output (IFC2416 only)

The switching output on the 6-pin pluggable screw terminal are electrically connected to the supply voltage.

The switching behavior (NPN, PNP, Push-Pull) is programmable, I_{max} 70 mA.

The maximum auxiliary voltage for a switching output with NPN switching behavior is 30 V.

➔ Connect Pins 6 and 5 to the downstream evaluation unit; cable length less than 30 meters.

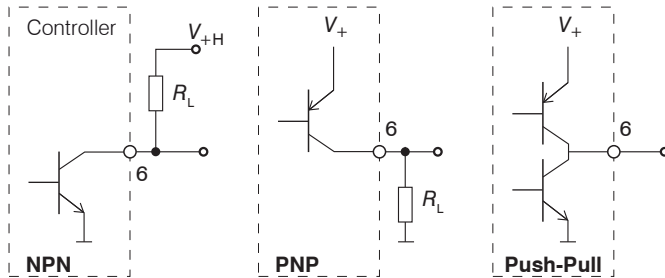

Description	Output active	Output passive
NPN (Low side)	GND	V_+
PNP (High side)	V_+	GND
Push-Pull	V_+	GND
Push-Pull, negiert	GND	V_+

RS422 Communication

In addition to Ethernet, the controller also supports serial communication via RS422. Serial communication is possible with SC2415-x/OE cables.

Properties: Differential signals according to EIA-422, galvanically connected to the supply voltage.

➔ Use a shielded cable with twisted wires. Cable length less than 30 m.

➔ Connect the ground connections.

Controller 17-pin connector	Signal	SC2415-x/OE	IF2001/USB
3	TX -	Black	RX -
13	TX +	Purple	RX +
10	RX +	Brown	TX +
11	RX -	White	TX -
Housing	Shield	Cable shield	---

The IFC2411/2416 controllers support one encoder. Without serial communication via RS422 the IFC2416 controller supports up to three encoders.

Multifunction Button

The Multifunction button is assigned multiple functions. As default, the button is assigned the Dark reference function.

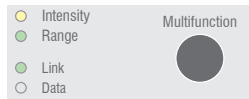

Function	Dark reference	Starts dark referencing
	Factory setting	Reset the device and measurement settings to factory settings.

The selected function is indicated by the flashing/illuminated Range and Intensity LEDs.

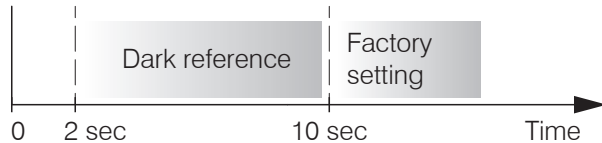

The Multifunction button is not assigned a key lock in the factory. Optionally, you can deactivate or lock the Multifunction button, see the operating instructions for the controller.

Multifunction button actuation time

Controller LEDs

LED	Color	Status	Meaning
Intensity	Red	flashes	Dark signal acquisition in progress
	Red	lights up	Signal saturated
	Yellow	lights up	Signal too low
	Green	lights up	Signal OK
Range	Red	flashes	Dark signal acquisition in progress
	Red	lights up	No target present, outside of measuring range
	Yellow	lights up	Target close to mid of measuring range
	Green	lights up	Measuring object within the measuring range

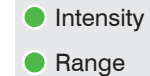

Sensor Cable, Optical Fiber

Sensor and controller are connected through an optical fiber.

- Do not shorten or lengthen the optical fibers.
- Do not pull or hold the sensor on the optical fiber.

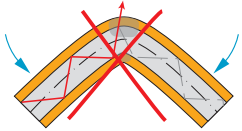

Do not kink the sensor cable.

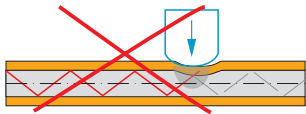

Please do neither squeeze the sensor cable nor fix it by using cable ties.

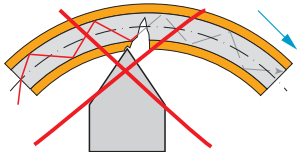

Please do not grind the sensor cable over sharp corners.

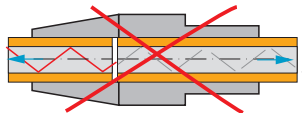

Do not pull the sensor cable.

Cleaning of the connectors requires the corresponding know-how.

Basic Rules

Avoid

- any contamination of the connector, e. g. dust
- any mechanical stress of the fiber
- strong bending of the fiber

Please never underrun the allowed bending radius.

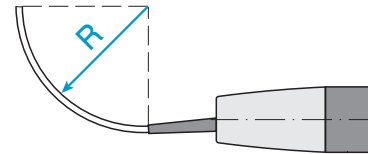

Fixed:

$R = 30 \text{ mm}$ or more

Flexible:

$R = 40 \text{ mm}$ or more

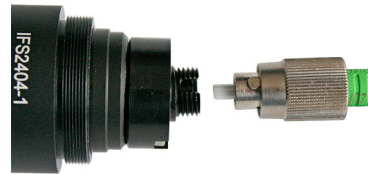

Socket groove on the sensor (left) and guiding peg of an FC sensor plug (right)

Fiber optic and sensor

- Note the orientation of the socket and the guiding peg.

Initial Operation

- The measuring system is ready for operation approx. 3 s after applying the supply voltage.
- 1 To ensure precise measurements, let the measuring system warm up for about 50 minutes.

The controller starts with Ethernet.

Communication with the sensor

Ethernet Communication

- Programming via web interface
- Data output via Ethernet
- Programming on command level e.g. with Telnet

- ➡ Connect the controller and the PC with a LAN cable.
- ➡ Start your web browser and type the default IP address 169.254.168.150 of the controller into the address bar.

RS422 Communication ¹

- Programming via web interface
- Programming on command level e.g. with Telnet
- Data output via RS422

- ➡ Connect the sensor, e.g. via an IF2001/USB RS422 converter from Micro-Epsilon via USB to a PC.

- ➡ Start the `sensorTOOL` program.

Download at <https://www.micro-epsilon.de/download/software/sensorTOOL.exe>.

- ➡ Click the `Sensor` button.

The program will now search for connected sensors.

- ➡ Select a desired sensor. Click the `Open Website` button.

Saved settings remain in the controller remanently across interfaces

1) The IFC2411/2416 controllers support one encoder. Serial communication via RS422 is not possible with IFC2416 if two or three encoders should be connected.

Access via Web Interface

➡ Start the web interface of the controller, see section *Initial Operation*.

Interactive web pages you can use to configure the controller are now displayed in the web browser. The controller is active and supplies measurement values. The web interface does not guarantee real-time measurements. The currently running measurement can be controlled using the function buttons in the **Chart type** section.

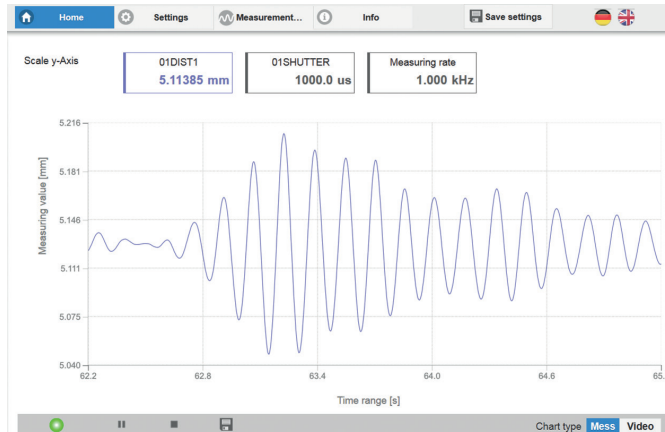

First page after web interface has been accessed in Ethernet mode

For configuration, you can switch between the video signal and a display of the measured values over time. The appearance of the websites depends on the functions. Dynamic help texts with excerpts from the operating instructions supports you during controller configuration.

• Depending on the selected measuring rate and the PC used, measured values may be reduced in the display. That is, not all measured values are transmitted to the web interface for display and saving.

The horizontal navigation includes the functions below:

- Home. The web interface automatically starts in this view with Measurement Chart, Measurement configuration and Signal quality.
- Settings. Sensor parameters configuration such as triggering, measuring rate and zero setting/mastering.
- Measurement chart. Measurement chart or video signal display.
- Info. Includes information about the controller, such as measuring range, serial number and software status.

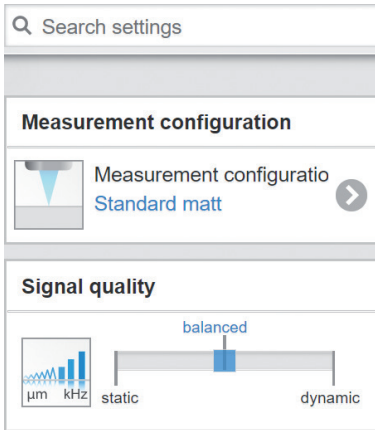

The vertical navigation is contextual to the selection in the horizontal navigation and contains the following functions for the Home menu:

- The Search settings function permits time-saving access to functions and parameters.
- Measurement configuration. Allows a selection of predefined measurement settings.
- Signal quality. By mouse click it is possible to switch between three predefined basic settings for the measuring rate and the averaging.

Positioning the Target

➡ Position the target as centrally as possible within the measuring range.

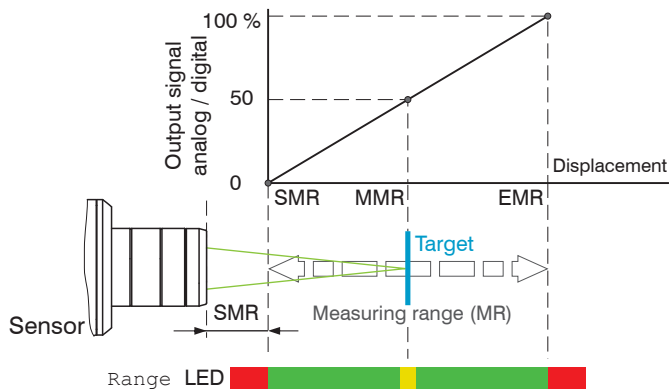

- Intensity
- Range

Range LED	
Red	No target present or target outside of measuring range
Yellow	Target close to mid of measuring range
Green	Measuring object within the measuring range

The Range LED on the front of the controller indicates the position of the target relative to the sensor.

Presets, Setups, Measurement Configuration, Signal Quality

Definition

- Preset: Manufacturer-specific program with settings for frequent measurement tasks; cannot be overwritten
- Setup: User-specific program with relevant settings for a measurement task
- Initial setup at boot (controller start): a favorite can be selected from the setups, which is automatically activated at start. If no favorite is determined from the setups, the controller activates the Standard preset at startup.

The image displays two screenshots of the Measurement configuration interface. The left screenshot shows the 'Measurement configuration' tab with 'Standard matt' selected. Below this, there is a 'Signal quality' section with a 'balanced' slider and a 'System configuration' section with 'Measuring rate' at 1.0, 'Exposure mode' at 'Measurement mode', 'Number of peaks' at 1, and 'Output interface' at 'Analog output'. The right screenshot shows the 'Measurement configuration' tab with a list of presets: 'Standard matt', 'Standard shiny', 'Multisurface', and 'One-sided thickness measurement', and a list of setups: 'F14_8_07' and 'F2_1_34'.

Upon delivery of the controller from the factory

- the presets Standard, Standard shiny, Multisurface and One-sided thickness measurement are possible
- for the IFD2416 controller, the presets Multilayer air gap and Multilayer laminated glass are available.
- no setup is available.

You can select a preset in the tab







Home > Measurement configuration

You can select a setup in the tab

Home > Measurement configuration or Settings in the System settings > Load & save menu

A setup can be stored permanently in the controller.

Presets allow a quick start into the individual measurement task. Basic features such as peak and material selection and the calculation functions are already set in the presets to match the target surface.

 Standard matt	Distance measurement, e.g., for ceramic material, non-transparent plastics. Highest peak, averaging, distance calculation.	 One-sided thickness measurement	One-sided thickness measurement, e.g., for glass, BK7 material. First and second peak, averaging, thickness calculation.
 Standard shiny	Distance measurement, e.g., for metal, polished surfaces. Highest peak, Median over 5 values, distance calculation.	 Multilayer air gap	One-sided thickness measurement ¹ against glass, 1st layer BK7, 2nd layer vacuum, first and second peak, 3 measured values, median over five values, thickness calculation.
 Multisurface	Distance measurement, e.g., for PCBs, hybrid materials. Highest peak, Median over 9 values, distance calculation.	 Multilayer laminated glass	Layer thickness measurement ¹ against laminated glass e.g. windshield, 1st layer BK7, 2nd layer PC, 3rd layer BK7, first and second peak, 4 measured values, thickness calculation,

For all presets, the measurement task can be individually adapted via the **Signal quality** slider. Reducing the measuring rate increases the exposure time for the line and thus improves the measurement quality.

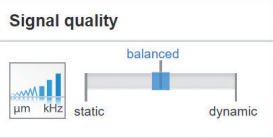
Signal quality	Measuring rate ²	Averaging ²	Description
	0.2 kHz	Static Moving, 128 values	Three predefined basic settings (Static, Balanced and Dynamic); a change via mouse click is immediately visible in the diagram and the system configuration. i If the controller starts up with a user-defined measurement setting (setup), the signal quality cannot be changed.
	1 kHz	Balanced Moving, 16 values	
	5 kHz	Dynamic Moving, 4 values	

1) Available with controller IFC2416 only.

2) Values apply to the **Standard** and **One-sided thickness measurement** presets.

Checking the Video Signal, Peak Selection

The video signal shows the determined reflections at the measuring object as a raw signal. The peaks are counted starting at the start of the measuring range toward the end of the measuring range. The corresponding measured value is marked by a vertical line (peak marking).

➡ Go to the **Measurement** chart menu. Display the video signal with **Video**. Adjust the settings for the exposure mode and measuring rate parameters.

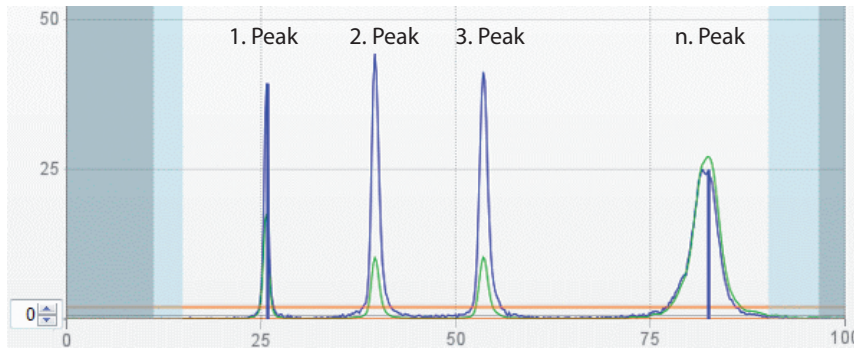

The selection of peaks dictates which region in the signal is used for the distance or thickness measurement. For a measuring object consisting of several transparent layers, use the refractive index correction to compensate for the distance measurement errors caused by optical factors, see operating instructions.

Video signal of transparent measuring object with four peaks (optical boundary areas) in the measuring range

1 measurement	first peak / highest peak / last peak
2 measurement values	first and second peak / first and last peak / second to last and last peak / highest and second highest peak
3 measurements	All peaks above the intensity threshold are evaluated in ascending distance order.
4 measurements	
5 measurements	The controller IFC2416 enables up to six measurements.
6 measurements	

The **Standard**, **Standard shiny** and **Multisurface** presets use the highest peak.

The preset **One-sided thickness measurement** uses the 1. and 2. peak for the calculation of the measured value.

➡ Go to the **Data Recording** > **Settings** > **Peak selection** menu to select a different peak.

Distance Measurement with Website Display

➡ Align the sensor perpendicularly to the object to be measured.

➡ Then, move the sensor (or the target) closer and closer to the start of the measuring range of the relevant sensor.

As soon as the object is within the measuring field of the sensor, the controller's Range LED lights up (green or yellow). Alternatively, you can watch the video signal.



Measurement (*distance measurement*) web page

- 1 Stop pauses the chart; you can still use the data selection and zoom functions. Save opens a Windows selection dialog for the file name and storage location to save the last 10,000 values in a CSV file (separation using semicolon).
- 2 All changes only become effective when you click on the Save settings button.
- 3 In the left-hand window, the signals to be displayed can be switched on or off during or after the measurement. Inactive curves are grayed out and can be added by clicking on the check mark. The changes become effective when you save the settings.
You can show or hide the individual signals using the eye symbols . The calculation continues in the background.
 - 01SHUTTER: exposure time
 - 01xINTENSITY: Signal quality of the underlying peak in the video signal
 - 01DIST: Distance signal curve over time
- 4 To scale the axis in the graph for the measured values (y-axis), you can use Auto (= automatic scaling) or Manual (= manual scaling).
- 5 The current values for distance, exposure time, current measuring rate and time stamp are shown in the text boxes above the graph. Errors are also displayed.
- 6 Mouseover function. When the chart has been stopped and you move the mouse over the graph, points on the curve are marked with a circle and the associated values are displayed in the text boxes above the graph. The intensity bars are also updated.
- 7 The peak intensity is displayed as a bar chart.
- 8 Scaling the x-axis: During an ongoing measurement, you can use the left-hand slider to enlarge the entire signal (zoom). The time range can also be defined using an input field under the time axis. When the chart has been stopped, the right-hand slider can also be used. You can also move the zoom window with the mouse in the center of the zoom window (four-sided arrow).

One-Sided Thickness Measurement, Transparent Target

The controller evaluates two signals reflected on the surfaces. Based on these two signals, the sensor calculates the distances from the surfaces and, from this, derives the thickness.

- ➔ Align the sensor perpendicularly to the object to be measured. Make sure that the target is approximately in the mid of the measuring range ($SMR + 0.5 \times MR$).
- ⓘ The light beam must strike the surface of the object at a perpendicular angle. Otherwise, measurements might be inaccurate.

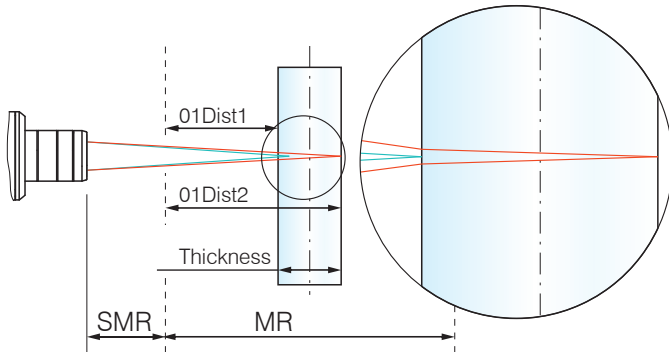

One-sided thickness measurement for a transparent target

Preset Selection

- ➔ Switch to the Home menu.
- ➔ Select **Multilayer air gap** or **Multilayer laminated glass** preset in the Measurement configuration menu.

This presetting prompts the sensor to use the first and second peak in the video signal for the thickness calculation.

Material Selection

Specifying the material is essential for calculating a correct thickness value. To compensate for the spectral change of the index of refraction, at least three refractive indices at different wavelengths or a refractive index and the Abbe number must be known.

The material table includes predefined materials.

- ➔ Switch to the Settings > Data recording > Material selection menu.
- ➔ Select the material of the target for Layer 1.

Layer Thickness Measurement, Transparent Target

This function is available with the IFC2416 controller. The controller evaluates signals reflected at the surfaces. The controller uses the max. 6 possible signals to calculate the distances from the surfaces and from this the thickness.

- ➔ Align the sensor perpendicularly to the object to be measured. Make sure that the target is approximately in the mid of the measuring range (SMR + 0.5 x MR).

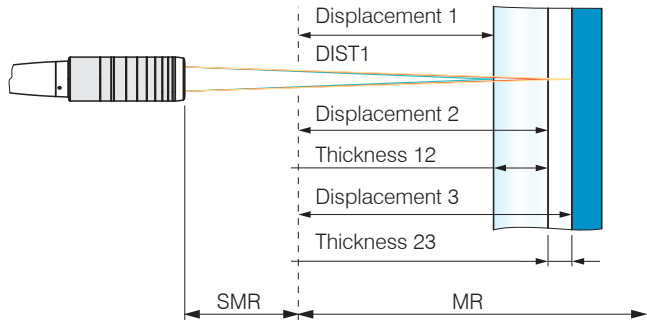

Measurement of a transparent target with multiple layers

Preset Selection

- ➔ Switch to the Home menu.
- ➔ In the Measurement configuration menu, select the Multilayer air gap or Multilayer laminated glass preset.

Peak Selection

The number of peaks is equivalent to the number of transitions between different materials of a target within the measuring range.

- ➔ Switch to Settings > Data recording > Peak selection and select the required peaks.

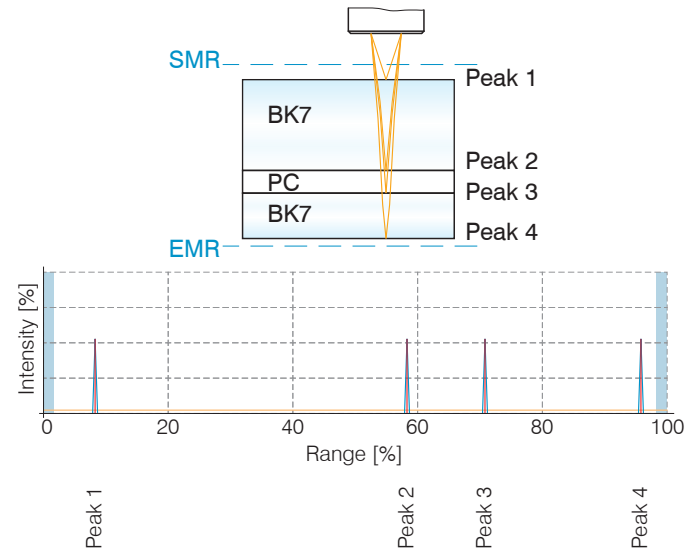

Transparent target with three layers

Video Signal

If a surface of the target lies outside the measuring range, the controller will send only one signal for the displacement, intensity and center of gravity. This may also occur if a signal is below the detection threshold. Two boundary surfaces are active when the correct thickness of a transparent material is measured. As a result, two peaks are visible in the video signal.

Video signal (*thickness measurement*)

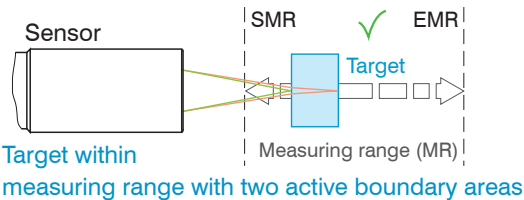
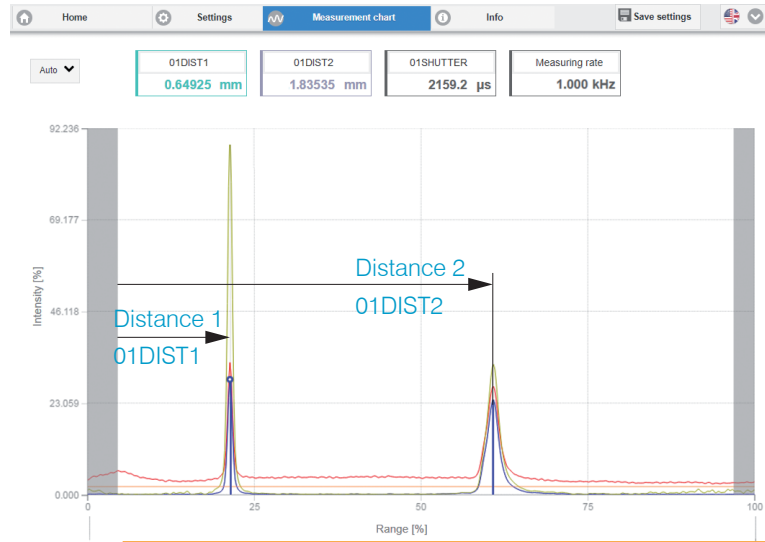

Measurement arrangement for thickness measurement

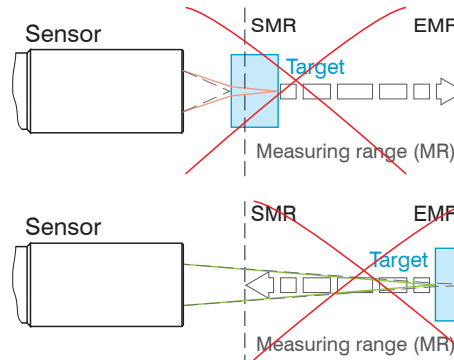

No thickness measurement possible

Measuring object only partially in the measuring range

Material Selection

Specifying the material is essential for calculating a correct thickness value. To compensate for the spectral change of the index of refraction, at least three refractive indices at different wavelengths or a refractive index and the Abbe number must be known.

- ➡ Switch to the Settings > Data recording > Material selection menu.
- ➡ Assign the materials to the individual layers according to the target used.

Measurement Chart for Thickness Measurement

- ➡ Switch to the Measurement chart tab and select Mess as the chart type.

The web page shows the two distances and the thickness Ch01Thick12 (difference between 01DIST2 and 01DIST1) graphically and numerically. Optionally, the intensities of both peaks (Peak 1 = near, Peak 2 = far) can also be displayed.



Data Format Ethernet Interface

All measurement data and the header are transmitted in little-endian format. A data packet typically contains one or more measurement data frames.

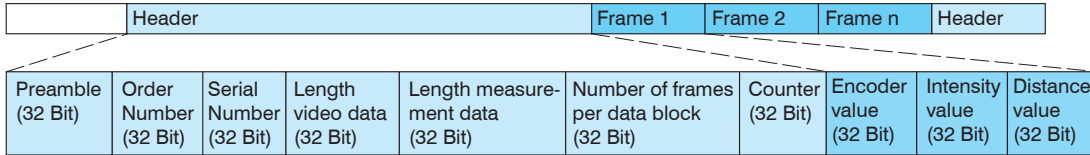

Example for data transmission with Ethernet

Output value	Ethernet, min	Ethernet, max	Scaling	Unit
01RAW (512 x 16Bit)	0	4095	value / 4096 * 100	%
01SHUTTER	0	UINT32_MAX	value / 36	μ s
01ENCODER1	0	UINT32_MAX	value	Ticks
01ENCODER2	0	UINT32_MAX	value	Ticks
01ENCODER3	0	UINT32_MAX	value	Ticks
01INTENSITY[1..6]	0	0x3ffffff	(value & 0x7ff) / 1024 * 100	%
01DIST[1..6]	INT32_MIN	0x7ffffeff	value / 1000000	mm
01SYMM[1..6]	INT32_MIN	INT32_MAX	value / 262144	Center
MEASRATE (IFC2411)	4500	360000	36000 / value	kHz
MEASRATE (IFC2416)	1440	360000	36000 / value	kHz
TIMESTAMP	0	UINT32_MAX	value	μ s
COUNTER	0	UINT32_MAX	value	
_MIN	INT32_MIN	0x7ffffeff	identical with 01DIST	nm
_PEAK	INT32_MIN	0x7ffffeff	identical with 01DIST	nm
_MAX	INT32_MIN	0x7ffffeff	identical with 01DIST	nm

Extract of output values with Ethernet

Data Format RS422 Interface

The output of distance measurement values and other measured values via RS422 requires subsequent conversion into the relevant unit. The measurement data, if requested, always follows a video frame.

Output value 1:

	Preamble		Data bits					
L-Byte	0	0	D5	D4	D3	D2	D1	D0
M-Byte	0	1	D11	D10	D9	D8	D7	D6
H-Byte	1	0	D17	D16	D15	D14	D13	D12

Output value 2 ... 32:

	Preamble		Data bits					
L-Byte	0	0	D5	D4	D3	D2	D1	D0
M-Byte	0	1	D11	D10	D9	D8	D7	D6
H-Byte	1	1	D17	D16	D15	D14	D13	D12

The instruction manual contains a complete list of the output values.

Output value	RS422, min	RS422, max	Scaling	Unit
01RAW (512 x 16Bit)	0	4095	$\text{value} / 4096 * 100$	%
01SHUTTER	0	65536	$\text{value} / 9$	μs
01ENCODER1	0	262143	value	Ticks
01Intensity	0	2028	$\text{value} / 1024 * 100$	%
01DIST[1..6]	0	262071	$(\text{value} - 98232) / 65536 * \text{measuring range}$	mm
MEASRATE (IFC2411)	2250	180000	$18000 / \text{value}$	kHz
MEASRATE (IFC2416)	720	180000	$18000 / \text{value}$	kHz
TIMESTAMP	0	262143	value	μs
TIMESTAMP_HI	0	65535	$\text{value} * 65536$	μs
TIMESTAMP_LO	0	65535	value	μs

Extract of output values with RS422

Service, Repair

If the sensor, controller or sensor cable is defective:

- If possible, save the current sensor settings in a parameter set to reload them into the controller after the repair.
- Please send us the affected parts for repair or exchange.

If the cause of a fault cannot be clearly identified, please send the entire measuring system to:

MICRO-EPSILON MESSTECHNIK
GmbH & Co. KG

Koenigbacher Straße 15
94496 Ortenburg / Germany

Tel. +49 (0) 8542 / 168-0

Fax +49 (0) 8542 / 168-90

info@micro-epsilon.com

www.micro-epsilon.com

Disclaimer

All components of the device have been checked and tested for functionality in the factory. However, should any defects occur despite careful quality control, these shall be reported immediately to Micro-Epsilon or to your distributor/retailer.

Micro-Epsilon undertakes no liability whatsoever for damage, loss or costs caused by or related in any way to the product, in particular consequential damage, e.g., due to

- non-observance of these instructions/this manual,
- improper use or improper handling (in particular due to improper installation, commissioning, operation and maintenance) of the product, repairs or modifications by third parties,
- the use of force or other handling by unqualified persons.

This limitation of liability also applies to defects resulting from normal wear and tear (e.g., to wearing parts) and in the event of non-compliance with the specified maintenance intervals (if applicable).

Micro-Epsilon is exclusively responsible for repairs. It is not permitted to make unauthorized structural and / or technical modifications or alterations to the product. In the interest of further development, Micro-Epsilon reserves the right to modify the design or the firmware.

In addition, the General Terms of Business of Micro-Epsilon shall apply, which can be accessed under Legal details | Micro-Epsilon <https://www.micro-epsilon.com/legal-details>.

Decommissioning, Disposal

In order to avoid the release of environmentally harmful substances and to ensure the reuse of valuable raw materials, we draw your attention to the following regulations and obligations:

- Remove all cables from the sensor and/or controller.
- Dispose of the sensor and/or controller, its components and accessories, as well as the packaging materials in compliance with the applicable country-specific waste treatment and disposal regulations of the region of use.
- You are obliged to comply with all relevant national laws and regulations

For Germany / the EU, the following (disposal) instructions apply in particular:

- Waste equipment marked with a crossed garbage can must not be disposed of with normal industrial waste (e.g. residual waste can or the yellow recycling bin) and must be disposed of separately. This avoids hazards to the environment due to incorrect disposal and ensures proper recycling of the old appliances.
- A list of national laws and contacts in the EU member states can be found at https://ec.europa.eu/environment/topics/waste-and-recycling/waste-electrical-and-electronic-equipment-weee_en. Here you can inform yourself about the respective national collection and return points.
- Old devices can also be returned for disposal to Micro-Epsilon at the address given in the legal details at <https://www.micro-epsilon.com/legal-details>.
- We would like to point out that you are responsible for deleting the measurement-specific and personal data on the old devices to be disposed of.
- Under the registration number WEEE-Reg.-Nr. DE28605721, we are registered at the foundation Elektro-Altgeräte Register, Nordostpark 72, 90411 Nuremberg, as a manufacturer of electrical and/or electronic equipment.





MICRO-EPSILON MESSTECHNIK GmbH & Co. KG
Koenigbacher Str. 15 · 94496 Ortenburg / Germany
Tel. +49 (0) 8542 / 168-0 · Fax +49 (0) 8542 / 168-90
info@micro-epsilon.com · www.micro-epsilon.com
Your local contact: www.micro-epsilon.com/contact/worldwide/

X9691458.03-A022036MSC
© MICRO-EPSILON MESSTECHNIK