



Operating Instructions
opto**NCDT** 5500 EtherCAT

ILD5500-10 ILD5500-100
ILD5500-25 ILD5500-200
ILD5500-50

Intelligent laser-optical displacement measurement

MICRO-EPSILON MESSTECHNIK
GmbH & Co. KG
Koenigbacher Str. 15

94496 Ortenburg / Germany

Tel: +49 (0) 8542 / 168-0
Fax: +49 (0) 8542 / 168-90
info@micro-epsilon.com
<https://www.micro-epsilon.com>

Contents

1	Safety.....	6
1.1	Symbols used.....	6
1.2	Warnings.....	6
1.3	Notes on product marking.....	6
1.3.1	CE marking.....	6
1.3.2	UKCA marking.....	7
1.4	Intended use.....	7
1.5	Proper environment.....	7
2	Laser safety.....	8
3	Functional principle, technical data.....	9
3.1	Short description.....	9
3.2	Advanced Surface Compensation.....	9
3.3	Technical data.....	10
3.4	Technical data, measuring range.....	10
3.5	Control and indicator elements.....	11
4	Delivery.....	12
4.1	Unpacking, included in delivery.....	12
4.2	Storage.....	12
5	Installation.....	13
5.1	Notes on operation.....	13
5.1.1	Reflectance of target surface	13
5.1.2	Error influences.....	13
5.1.2.1	Ambient light.....	13
5.1.2.2	Color differences.....	13
5.1.2.3	Thermal influences.....	13
5.1.2.4	Mechanical vibrations.....	14
5.1.2.5	Motion blur.....	14
5.1.2.6	Surface Roughness.....	14
5.1.2.7	Angular influences.....	14
5.1.2.8	Error detection during peak evaluation - MR10 MR25 MR50.....	14
5.1.3	Optimization of measurement accuracy.....	15
5.2	Mechanical fastening.....	15
5.2.1	General.....	15
5.2.2	Mounting, dimensional drawing ILD5500.....	16
5.3	Electrical connections.....	18
5.3.1	RJ45 connection, PoE, laser on/off via software.....	18
5.3.2	RJ45 connection, PoE, laser on/off via hardware.....	18
5.3.3	RJ45 connection, supply via optional power supply unit, laser on/off via hardware.....	18
5.3.4	Pin assignment.....	19
5.3.5	Supply voltage.....	19
5.3.6	Turning on the laser.....	19
5.3.7	Plug connection, supply and output cables.....	20
6	Operation.....	21
6.1	Getting ready for operation.....	21
6.2	Operation via web interface.....	21
6.2.1	General.....	21
6.3	Access via web interface.....	21
6.4	Presets, setups, selection of measurement configuration.....	22
6.5	Display of measurement values in the web browser.....	24
6.6	Video signal display in the web browser.....	25
6.7	Parameter setting via EtherCAT.....	26
6.8	Time response, measurement value flow.....	26
7	Setting sensor parameters, web interface.....	27
7.1	Preliminary remarks concerning the setting options.....	27
7.2	Overview of parameters.....	27
7.3	Laser power.....	27
7.4	Data acquisition.....	27
7.4.1	Preliminary remarks.....	27

7.4.2	Measuring rate.....	27
7.4.3	Measurement configuration.....	28
7.4.4	Measurement task.....	28
7.4.5	Masking the region of interest, ROI.....	28
7.4.6	Exposure mode.....	29
7.4.7	Peak selection.....	29
7.5	Signal processing.....	29
7.5.1	Preliminary remarks.....	29
7.5.2	Averaging.....	29
7.5.2.1	General.....	29
7.5.2.2	Moving mean.....	30
7.5.2.3	Recursive average.....	31
7.5.2.4	Median.....	31
7.6	Postprocessing.....	31
7.6.1	Zeroing, mastering.....	31
7.6.2	Statistics.....	32
7.7	System settings.....	32
7.7.1	General.....	32
7.7.2	Web interface unit.....	32
7.7.3	Language in the web interface.....	32
7.7.4	Loading, saving.....	33
7.7.5	Import, export.....	33
7.7.6	Access authorization.....	34
7.7.7	Reset sensor.....	35
8	Industrial Ethernet data output.....	36
9	EtherCAT.....	37
9.1	Preliminary remarks.....	37
9.2	Saving the settings, continuing EtherCAT® mode.....	37
10	Cleaning.....	38
11	Software support with MEDAQLib.....	39
12	Disclaimer.....	40
13	Service, repair.....	41
14	Decommissioning, disposal.....	42
15	Optional accessories.....	43
16	Factory settings.....	44
17	Switch between EtherCAT® and Ethernet setup mode.....	45
18	Switch between Ethernet Setup mode and EtherCAT®.....	46
19	EtherCAT documentation.....	47
19.1	General.....	47
19.2	Introduction.....	47
19.2.1	Structure of EtherCAT® frames.....	47
19.2.2	EtherCAT®Services.....	47
19.2.3	Addressing and FMMUs.....	48
19.2.4	Sync manager.....	48
19.2.5	EtherCAT® state machine.....	48
19.2.6	CANopen via EtherCAT®.....	48
19.2.7	Prozessdaten PDO-Mapping.....	49
19.2.8	Service data SDO service.....	49
19.3	CoE object directory.....	49
19.3.1	Communication-specific standard objects.....	49
19.3.1.1	Overview.....	49
19.3.1.2	Object 1001h: Device type.....	50
19.3.1.3	Object 1008h: Manufacturer device name.....	50
19.3.1.4	Object 1009h: Hardware version.....	50
19.3.1.5	Object 100Ah: Software version.....	50
19.3.1.6	Object 100B: Bootloader.....	50
19.3.1.7	Object 1018h: Device identification.....	50
19.3.1.8	TxPDO mapping.....	51
19.3.1.9	Object 1C00h: Synchronous manager type.....	53
19.3.1.10	Object 1C12h: RxPDO assign.....	54





19.3.1.11	Object 1C13h: TxPDO assign.....	54
19.3.1.12	Object 1C32h: Sync manager output parameters.....	54
19.3.1.13	Object 1C33h: Sync manager input parameters.....	54
19.3.2	Manufacturer-specific objects.....	55
19.3.2.1	Object 3000h: Light source.....	56
19.3.2.2	Object 3002: Sensor error.....	56
19.3.2.3	Object 3005: Controller info.....	57
19.3.2.4	Object 3020: Synchronization.....	57
19.3.2.5	Object 3100: Measuring.....	57
19.3.2.6	Object 3101: Measurement task.....	57
19.3.2.7	Object 3102: Counter reset.....	57
19.3.2.8	Object 3103: Range of interest.....	58
19.3.2.9	Object 3104: Exposure.....	58
19.3.2.10	Object 3105: Peak selection.....	58
19.3.2.11	Object 3107: Field linearization.....	58
19.3.2.12	Object 3200: Comp available signals.....	59
19.3.2.13	Object 3210...3219: Comp.....	59
19.3.2.14	Object 3300: Mastering available signals.....	59
19.3.2.15	Object 3310...3319: Mastering.....	59
19.3.2.16	Object 3320: Statistic available signals.....	59
19.3.2.17	Object 3330...3339: Statistic.....	60
19.3.2.18	Object 3350: Signals on user calcs.....	60
19.3.2.19	Object 3501: Basic settings.....	60
19.3.2.20	Object 3350: Signals on user calcs.....	60
19.3.2.21	Object 3510: User level.....	61
19.3.2.22	Object 3520: Reset.....	61
19.3.2.23	Object 3521: Factory reset.....	61
19.3.2.24	Object 3530: Laser power.....	61
19.4	Mappable objects - process data.....	61
19.4.1	General.....	62
19.4.1.1	Object 6000: Exposure time.....	62
19.4.1.2	Object 6001: Measurement frequency.....	62
19.4.1.3	Object 6002: Time stamp.....	62
19.4.1.4	Object 6003: Measurement counter.....	63
19.4.1.5	Object 6004: Frame status.....	63
19.4.1.6	Object 6005: distance value, not linearized.....	63
19.4.1.7	Object 6006: Intensity.....	63
19.4.1.8	Object 6007: Distance value, linearized.....	64
19.4.1.9	Object 6008: Peak distance.....	64
19.4.1.10	Object 7000...7009: User calc.....	64
19.4.1.11	Object 700A...700F: User calc.....	64
19.4.1.12	Object 7010...7019: User calc.....	65
19.4.1.13	Object 701A...701F: User calc.....	65
19.4.1.14	Object 7020...7027: User calc.....	66
19.4.2	Error codes for SDO services.....	66
19.4.3	Oversampling.....	67
19.4.4	Update.....	68
19.4.4.1	Update via FoE.....	68
19.4.4.2	Update via EoE.....	68
19.4.5	Operational modes.....	68
19.4.5.1	Free run.....	68
19.4.5.2	Distributed clocks SYNC0 synchronization.....	68
19.4.5.3	SM2/SM3 synchronization.....	69
19.4.6	Meaning of the RUN and ERR LEDs for EtherCAT operation.....	69
19.4.7	EtherCAT®Configuration with the Beckhoff TwinCAT® Manager.....	69
	Index.....	72

1 Safety

1.1 Symbols used

System operation assumes knowledge of the operating instructions.

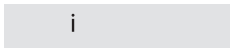
The following symbols are used in these operating instructions:



 CAUTION	Indicates a hazardous situation which, if not avoided, may result in minor or moderate injury.
 NOTICE	Indicates a situation that may result in property damage if not avoided.
	Indicates a user action.
 i	Indicates a tip for users.
 m	Indicates hardware or a software button/menu.

1.2 Warnings

Do not expose yourself to unnecessary laser radiation.

- ▶ Switch off the sensor for cleaning and maintenance.
- ▶ Switch off the sensor for cleaning and maintenance if the sensor is integrated into a system.

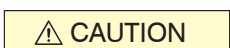
Caution - the use of controls or settings or the performance of procedures not specified in the operating instructions may cause damage.

 CAUTION	<p>Connect the power supply according to the regulations for electrical equipment.</p> <ul style="list-style-type: none"> • Risk of injury • Damage to or destruction of the sensor
 NOTICE	<p>Avoid knocks and impacts to the sensor.</p> <ul style="list-style-type: none"> • Damage to or destruction of the sensor <p>Only attach the sensor to the existing mounting holes/threaded holes on a flat surface; clamping of any kind is not permitted.</p> <ul style="list-style-type: none"> • Damage to or destruction of the sensor <p>The supply voltage must not exceed the specified limits.</p> <ul style="list-style-type: none"> • Damage to or destruction of the sensor <p>Protect the sensor cable from damage. Attach the cable load-free, catch the cable after approx. 25 cm and catch the pigtail on the plug, e.g. with cable ties.</p> <ul style="list-style-type: none"> • Destruction of the sensor • Failure of the measuring device <p>Avoid constant exposure of the sensor to splashes of water.</p> <ul style="list-style-type: none"> • Damage to or destruction of the sensor <p>Avoid exposure of sensor to aggressive media (detergents, cooling emulsions).</p> <ul style="list-style-type: none"> • Damage to or destruction of the sensor

1.3 Notes on product marking

1.3.1 CE marking

The following apply to the product:

- Directive 2014/30/EU ("EMC")
- Directive 2011/65/EU ("RoHS")

Products which carry the CE marking satisfy the requirements of the EU Directives cited and the relevant applicable harmonized European standards (EN).

The product is designed for use in industrial and laboratory environments.

The EU Declaration of Conformity and the technical documentation are available to the responsible authorities according to the EU Directives.

1.3.2 UKCA marking

The following apply to the product:

- SI 2016 No. 1091 ("EMC")
- SI 2012 No. 3032 ("RoHS")

Products which carry the UKCA marking satisfy the requirements of the directives cited and the relevant applicable harmonized standards.

The product is designed for use in industrial and laboratory environments.

The UKCA Declaration of Conformity and the technical documentation are available to the responsible authorities according to the UKCA Directives.

1.4 Intended use

The sensor is designed for use in industrial and laboratory environments.

It is used for

- Displacement, distance, position and thickness measurements
- Monitoring Quality and Checking Dimensions

The sensor must only be operated within the values specified in the technical data.

The sensor must be used in such a way that no persons are endangered and no machines or other physical items of property are damaged in the event of malfunction or total failure of the sensor.

Take additional precautions for safety and damage prevention in case of safety-related applications.

1.5 Proper environment

Protection class:	IP67
Temperature range:	
- Operation:	0 ... +50 °C ^[1]
- Storage:	-20 ... +70 °C
Humidity:	5 ... 95 % RH (non-condensing)
Ambient pressure:	Atmospheric pressure

i The protection class is limited to water (no penetrating liquids, detergents, or similar aggressive media).

The protection class does not apply to optical windows, as contamination will impair or prevent their function.

optoNCDT 5500



EtherCAT® is a registered trademark and patented technology licensed by Beckhoff Automation GmbH, Germany.

[1] The specified value is only achieved by mounting on a metallic sensor holder. Good heat dissipation from the sensor to the holder must be ensured.

2 Laser safety

The sensor works with a semiconductor laser at a wavelength of 670 nm (visible/red).

The sensors fall within laser class 2. The laser is operated in pulsed mode, the maximum optical power is ≤ 1 mW. The pulse frequency depends on the set measuring rate (0.25 ... 20 kHz). The pulse duration of the peaks is controlled depending on the measuring rate and the reflectivity of the object being measured and can be 0.5 ... 3994.5 μ s.

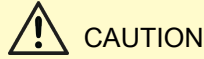

Laser radiation Eyes could become irritated or damaged. Close your eyes, or immediately turn away if the laser beam hits the eye.

Relevant regulations must be observed when operating the sensors. The following apply accordingly:

- With class 2 laser devices, the eye is not endangered by random, brief exposure to laser radiation, i.e. exposure times of up to 0.25 s.
- Class 2 laser devices may therefore be used without further protective measures if you do not intentionally look into the laser beam or into specular-reflected radiation for more than 0.25 s.
- Because the presence of the eyelid protective reflex should not normally be assumed, one should deliberately close the eyes or turn away immediately if the laser beam hits the eye.

Lasers of Class 2 are not subject to notification and a laser protection officer is not required.

The following signs are attached to the sensor housing:

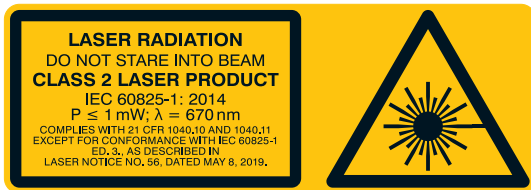

Fig. 2.1: Laser information and laser warning label

- i If the present information signs are covered over when the unit is installed, the user must ensure that supplementary information signs are attached at the installation location.

Operation of the laser is indicated visually by the LED on the sensor.

The housings of the optical sensors may only be opened by the manufacturer, [see Chap. 12](#).

For repair and service purposes, the sensors must always be sent to the manufacturer.

Observe national regulations, e.g., the German Occupational Health and Safety Ordinance on Artificial Optical Radiation (OStrV).

Recommendations for the operation of sensors that emit laser radiation in the visible or non-visible range can be found in DIN EN 60825-1 (from 07/2022), among others.

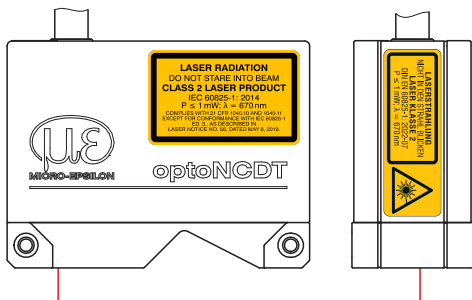

Fig. 2.2: Laser information and laser warning label on the sensor housing

3 Functional principle, technical data

3.1 Short description

The optoNCDT 5500 operates according to the principle of optical triangulation, i.e. a visible, modulated light spot is projected onto the surface of the measuring object.

The diffuse part of the reflection of this light spot is imaged on a spatial resolution element (CMOS) by a receiver optic arranged at a certain angle to the optical axis of the laser beam.

A signal processor in the sensor calculates the distances between the light spot on the target and the sensor from the output signal of the CMOS element. The distance value is linearized and output via the fieldbus interface.

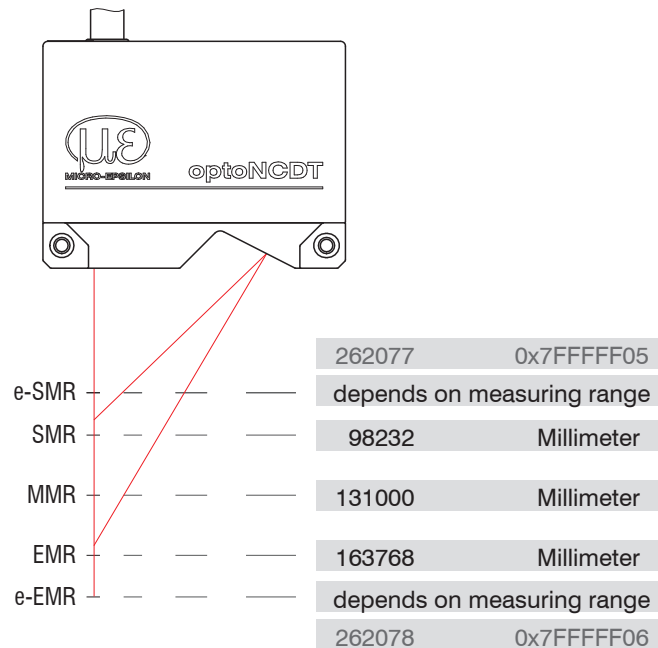

Fig. 3.1: Term definitions

e-SMR	Extended start of measuring range
SMR	Start of measuring range
MMR	Mid of measuring range
EMR	End of measuring range
e-EMR	Extended end of measuring range

The digital values apply to distance values without zeroing or mastering.

3.2 Advanced Surface Compensation

The sensor is equipped with intelligent surface control. New algorithms generate stable measurement results even on demanding surfaces where changing reflections occur. In addition, the new algorithms compensate for ambient light of up to 50,000 lux. The sensor therefore has the highest ambient light resistance in its class and can also be used in highly illuminated environments.

3.3 Technical data

General technical data		ILD5500-x with integrated Industrial Ethernet interface
Measuring rate ^[2]		0,25 kHz ... 20 kHz
Light source		Laser 670 nm
Laser class		Class 2 in accordance with IEC 60825-1: 2022-07
Supply voltage		12 ... 30 VDC
Power consumption		max. 5 W
Signal input		Laser on/off
Digital interface		EtherCAT / PROFINET
Switching output		1 or 2 switching outputs (error & limit value): npn, pnp, push pull
Connection		integrated pigtail 0.3 m with 12-pin M12 plug; optional extension to 3 m / 6 m / 9 m / 15 m (see accessories for suitable connection cables)
Mounting		Support points with locating holes for centering sleeves for reproducible clamping of the sensor 2 x M4 direct or M3 bolt connection
Temperature range	Storage	-20 ... 70 °C (non-condensing)
	Operation	0 ... 45 °C (non-condensing)
Shock (DIN EN 60068-2-27)		15 g / 6 ms in 3 axes
Vibration (DIN EN 60068-2-6)		50 g / 20 ... 500 Hz / max. displacement 3.6 mm
Protection class (DIN EN 60529)		IP67
Material		Aluminum housing
Weight		approx. 310 g (incl. pigtail)
Control and indicator elements ^[3]		Select key: factory settings, switching the operation mode; web interface for setup: application-specific presets, peak selection, video signal, freely selectable averaging possibilities, data reduction, setup management; 1 x color LED for power / status; 3 x color LEDs for "STATE", "RUN/SF", "ERR/BF"
Permissible ambient light ^[4]		≥ 200,000 lx

3.4 Technical data, measuring range

Model	ILD5500-10	ILD5500-25	ILD5500-50	ILD5500-100	ILD5500-200
Measuring range	10 mm	25 mm	50 mm	100 mm	200 mm
Start of measuring range	30 mm	40 mm	45 mm	70 mm	100 mm
Mid of measuring range	35 mm	52.5 mm	70 mm	120 mm	200 mm
End of measuring range	40 mm	65 mm	95 mm	170 mm	300 mm
Linearity ^[5]	< ±1.5 µm	< ±5 µm	< ±7.5 µm	< ±30 µm	< ±80 µm
	< ±0.015% FSO	< ±0,015% FSO	< ±0.015 % FSO	< ±0.03% FSO	< ±0.04% FSO
Repeatability ^[6]	< 0.008 µm	< 0.013 µm	< 0.021 µm	< 3 µm	< 4.5 µm

[2] Factory setting 4 kHz

[3] Access to web interface requires connection to PC

[4] ≥ 200,000 lx with background suppression | Default settings with 20 kHz measurement frequency: 50,000 lx

[5] Value applies only to the standard measuring range; value for median 9 + moving average 4096; Ethernet, 20 kHz, in the mid of the measuring range, on white, diffuse reflecting surfaces (Micro-Epsilon reference ceramic for optoNCDT sensors)

[6] Value valid only for the standard measurement range; value for median 9 + moving average 4096; Ethernet, 150 kHz, at the center of the measurement range, on a white, diffusely reflecting surface (Micro-Epsilon reference ceramic for optoNCDT sensors)

Model		ILD5500-10	ILD5500-25	ILD5500-50	ILD5500-100	ILD5500-200
Light spot diameter ^[7]	SMR	85 x 200 µm	140 x 310 µm	270 x 530 µm	200 x 500 µm	780 x 1800 µm
	MMR	60 x 75 µm	60 x 90 µm	130 x 150 µm	200 x 500 µm	780 x 1800 µm
	EMR	130 x 250 µm	230 x 380 µm	325 x 570 µm	640 x 1100 µm	780 x 1800 µm
	smallest Ø	30 x 47 µm with 34,5 mm	46 x 66 µm with 51,1 mm	58 x 82 µm with 68,1 mm	82 x 117 µm with 99 mm	-
Temperature stability ^[8]		± 0.008 % FSO / K			± 0.02 % FSO / K	

3.5 Control and indicator elements

State LED	Meaning
Green	Target within the measuring range
Yellow	Target in the mid of the measuring range
Red	No distance value available, e.g. measuring object outside the measuring range, reflection too low
Yellow flashing, 1 Hz	Bootloader
Yellow flashing, 8 Hz	Installation active
Yellow (briefly), red, yellow, green, off, alternating	Ethernet setup mode
Off	Laser switched off
LED RUN/SF	Meaning
	According to EtherCAT operation
LED ERR/BF	Meaning
	According to EtherCAT operation

Select button	Meaning
	Switching operating mode Resetting to factory setting

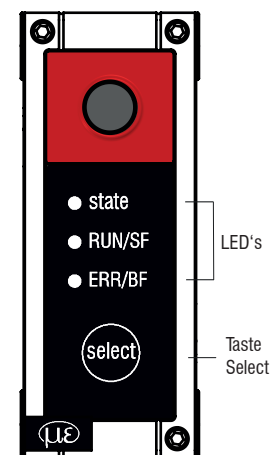

[7] ±20 %; SMR = start of measuring range; MMR = mid of measuring range; EMR = end of measuring range; light spot diameter determined with point-shaped laser with Gaussian fit (full 1/e² width)

[8] Related to digital output in the mid of the measuring range; the specified value is only achieved by mounting on a metallic sensor holder. Good heat dissipation from the sensor to the holder must be ensured.

4 Delivery

4.1 Unpacking, included in delivery

- 1 ILD5500 sensor
 - 1 setup guide
 - 2 laser warning labels in German, 2 laser warning labels in English, 2 laser warning labels in French
 - Accessories (2 pc. centering sleeves, 2 pc. M3 x 40)
- ▶ Carefully remove the components of the sensor from the packaging, handling them in such a way that no damage can occur.

i Do not touch the optical windows. Soiling of the optical windows will impair the functionality.

- ▶ Check the delivery for completeness and shipping damage immediately after unpacking.
- ▶ If there is damage or parts are missing, immediately contact the manufacturer or supplier.

Optional accessories are listed in the appendix.

Return of packaging

Micro-Epsilon Messtechnik GmbH & Co. KG offers customers the opportunity to return the packaging of products purchased from Micro-Epsilon by prior arrangement so that it can be reused or recycled.

To arrange the return of packaging, for questions about the costs and / or the exact return procedure, please contact us directly at

info@micro-epsilon.de

4.2 Storage

Temperature range:	-20 ... +70 °C
Humidity:	5 ... 95 % RH (non-condensing)

5 Installation

5.1 Notes on operation

5.1.1 Reflectance of target surface

In principle, the sensor evaluates the diffuse portion of the reflections of the laser light spot.

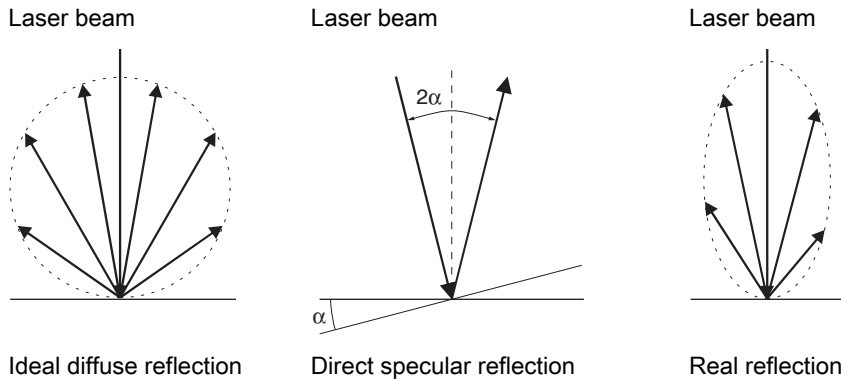

Tab. 5.1: Reflectance of target surface

Any statement about a minimum reflection factor is only possible with reservations, since small diffuse portions can be evaluated even of reflecting surfaces. This is done by determining the intensity of the diffuse reflection from the CMOS signal in real time and subsequent controlling, see Chap. 3.2 However, a longer exposure time may be required for dark or shiny objects, such as black rubber. The maximum exposure time is coupled to the measuring rate and can only be increased by lowering the measuring rate of the sensor.

5.1.2 Error influences

5.1.2.1 Ambient light

The sensors are very good at suppressing ambient light thanks to their built-in optical interference filter. However, ambient light disturbances can occur with shiny measuring objects and at a reduced measuring rate. In these cases it is recommended to provide shielding against ambient light or to switch on the `Background suppression` function. This applies in particular to measurement work performed in the vicinity of welding devices.

5.1.2.2 Color differences

Because of intensity compensation, color difference of targets affect the measuring result only slightly. However, such color differences are often combined with different penetration depths of the laser light into the material. Different penetration depths then result in apparent changes of the measuring spot size. Therefore color changes in combination with penetration depth changes may lead to measurement uncertainties.

5.1.2.3 Thermal influences

When the sensor is commissioned, a warm-up time of at least 30 minutes is required to achieve uniform heat distribution in the sensor.

If measurement is performed in the μm accuracy range, the effect of temperature fluctuations on the sensor holder must be considered.

Rapid temperature changes are not detected immediately due to the damping effect of the sensor's heat capacity.

i The `Temperature compensation` function requires software release V16.0 (Profinet V18.0, Ether-Cat V20.0) and is only upwards compatible. Correct calibration with lower versions is not possible.

5.1.2.4 Mechanical vibrations

If resolutions in the μm range are to be achieved with the sensor, particular attention must be paid to stable or vibration-damped sensor and target mounting.

5.1.2.5 Motion blur

If the objects being measured are fast moving and the measuring rate is low, it is possible that motion blurs may occur. Therefore, always select a high measuring rate for high-speed operations to prevent errors.

5.1.2.6 Surface Roughness

Laser-optical sensors detect the surface using an extremely small laser spot. They also track slight surface unevenness. In contrast, a tactile, mechanical measurement, e.g. with a caliper gauge, covers a much larger area of the measuring object. Surface roughnesses in the order of $5\ \mu\text{m}$ and more lead to an apparent change in distance with traversing measurements.

A suitable averaging number can improve the comparability of the optical and mechanical measurements.

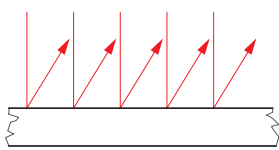

Ceramic reference surface

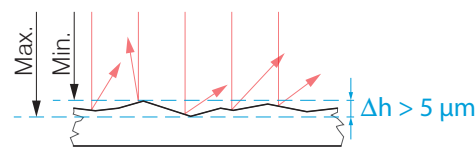

Structured surface

Recommendation for parameter choice:

Select the averaging number so that a comparably large surface area is averaged as for the mechanical measurement.

5.1.2.7 Angular influences

Target tilt angles around both the X and y-axis of less than 5° in the case of diffuse reflection only cause problems with surfaces that produce strong direct reflection.

These influences are particularly important when scanning profiled surfaces. In principle, angular behavior during triangulation is also affected by the reflectivity of the target surface.

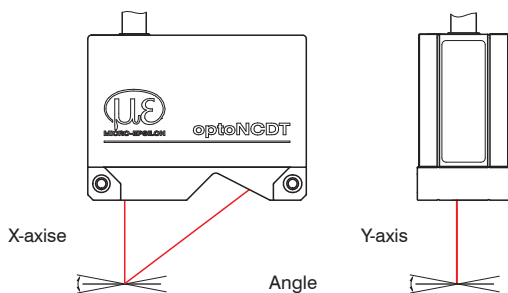

5.1.2.8 Error detection during peak evaluation - MR10 MR25 MR50

The ILD5500 is a highly sensitive optical sensor that measures even poorly diffusely reflective targets very quickly.

In principle, reflections may be detected that do not originate from the target itself, but from between the target and the optics or from within the optics. This may cause false detections during peak evaluation, especially with highly reflective targets and at low measurement frequencies.

- i Micro Epsilon recommends limiting the maximum possible shutter with `EXPOSURELIMIT`, especially at low measurement frequencies.

Measuring range	Recommended for measurement frequencies less than	Recommended value for EXPOSURELIMIT
10		
25	1 kHz	1000 μs
50	1.6 kHz	600 μs
100		
200		

5.1.3 Optimization of measurement accuracy

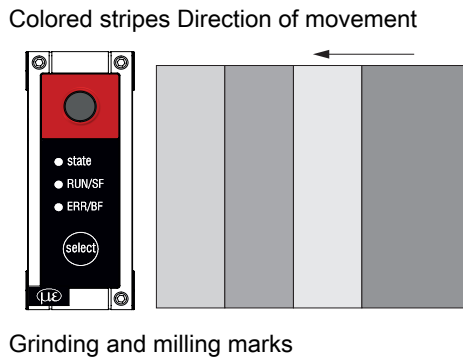

In case of rolled or polished metals that are moved past the sensor, the sensor plane must be arranged in the direction of the rolling or grinding marks. The same arrangement must be used for color strips.

Tab. 5.2: Sensor arrangement for sanded or striped surfaces

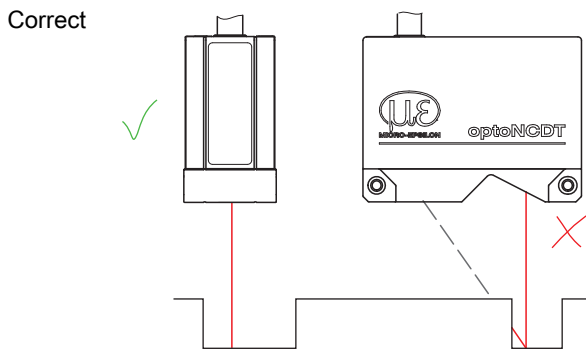

In case of bore holes, blind holes and edges in the surface of moving parts, the sensor must be arranged in such a way that the edge does not obscure the laser spot.

Tab. 5.3: Sensor arrangement for holes and edges

5.2 Mechanical fastening

5.2.1 General

The sensor is an optical system that measures in the μm range. If the laser beam does not strike the object surface at a perpendicular angle, measurements might be inaccurate.

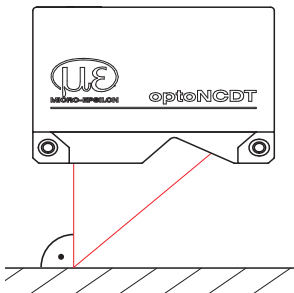

Fig. 5.1: Sensor mounting with diffuse reflection

The bearing surfaces surrounding the through-holes (fastening holes) are slightly raised.

- i Ensure careful handling of the sensor during installation and operation. Mount the sensor only to the existing through-bores on a flat surface. Any type of clamping is not permitted. Do not exceed torques.

5.2.2 Mounting, dimensional drawing ILD5500

Depending on the installation position, it is recommended to define the sensor position using centering elements and fitting bores. The cylindrical counterbore $\varnothing 6$ H7 is intended for the position-defining centering elements. This allows for the sensor to be mounted in a reproducible and exchangeable way.

Through-bolt connection

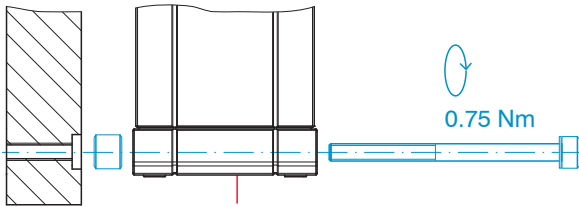

M3 x 40; ISO 4762, A2-70

Direct fastening

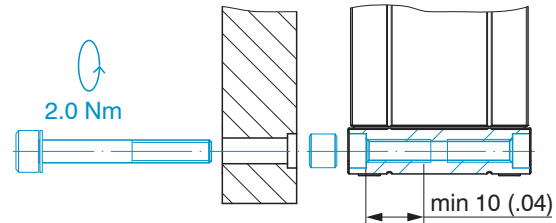

M4; ISO 4762, A2-70 | screw-in depth at least 10 mm

- i Only attach the sensor to the existing through-holes on a flat surface or screw it on directly. Clamps of any kind are not permitted.

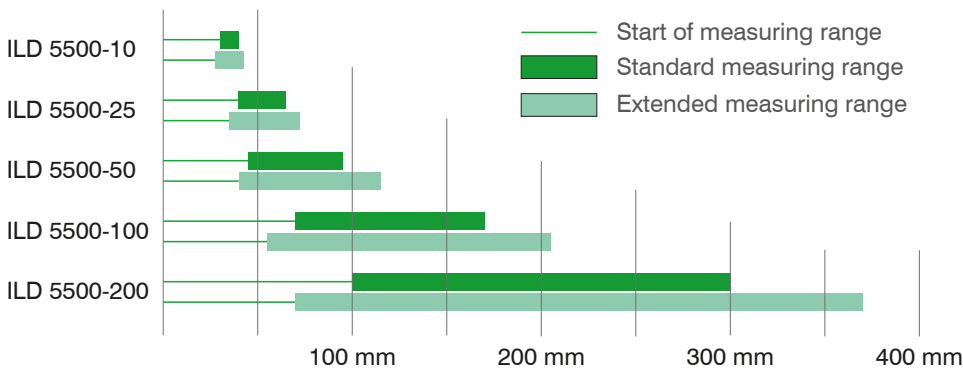

Fig. 5.2: Measuring range for distance measurement with extended and standard measuring range

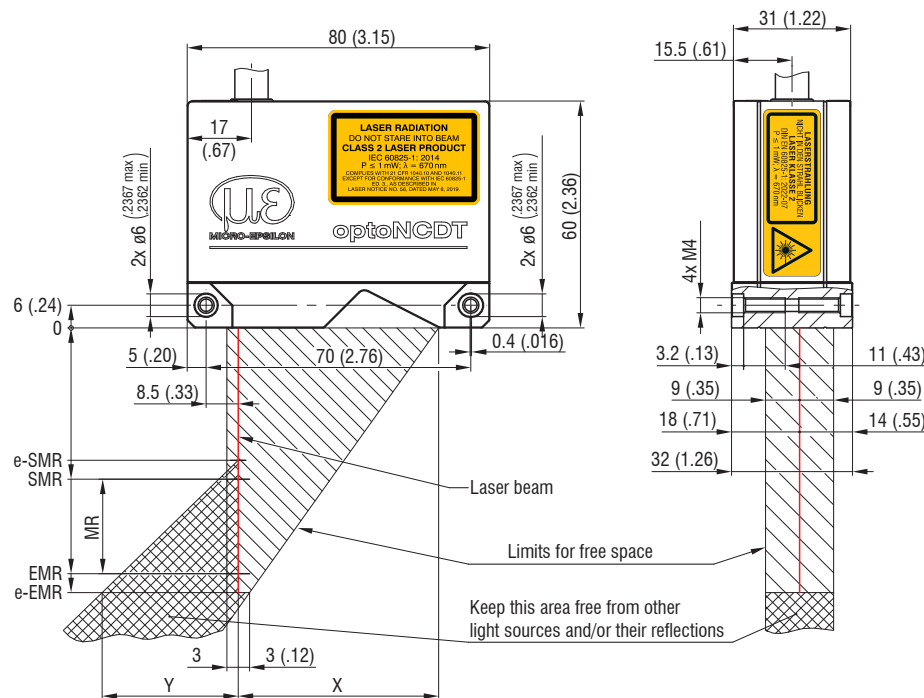

Fig. 5.3: Dimensional drawing ILD5500-10/25

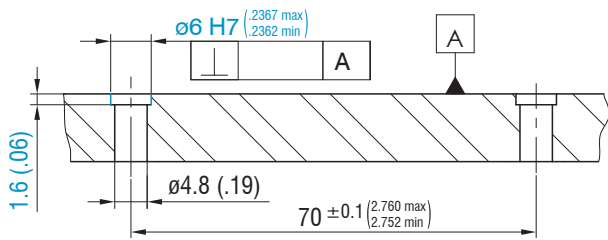
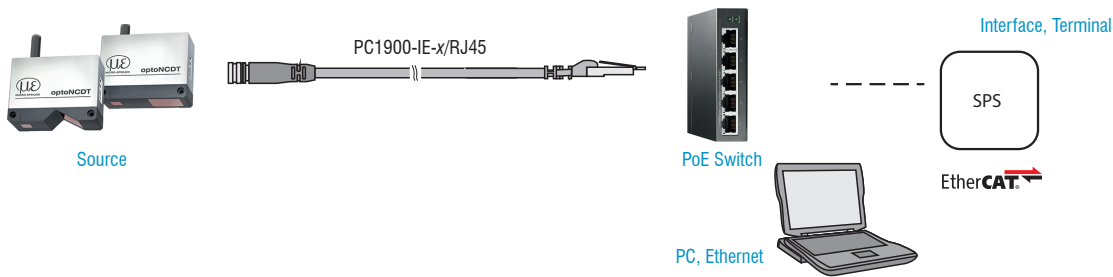

Fig. 5.5: Dimensional drawing of mounting plate

5.3 Electrical connections

5.3.1 RJ45 connection, PoE, laser on/off via software



5.3.2 RJ45 connection, PoE, laser on/off via hardware

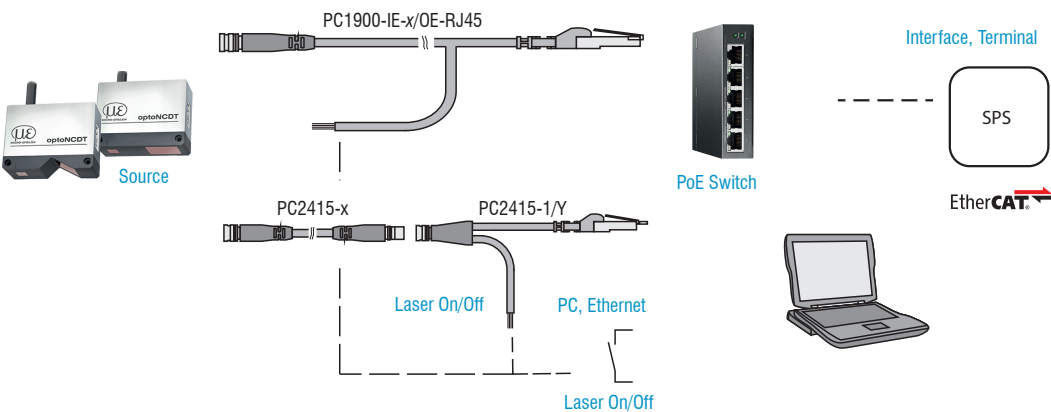

5.3.3 RJ45 connection, supply via optional power supply unit, laser on/off via hardware

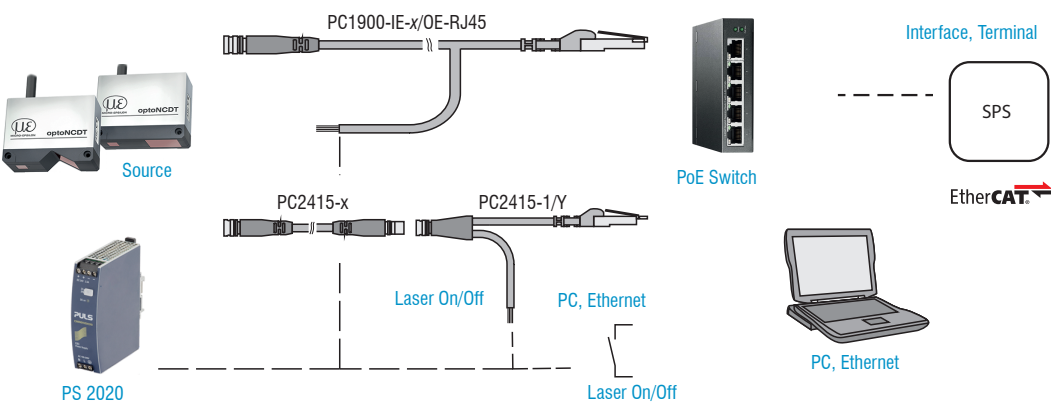

5.3.4 Pin assignment

Signal	Pin Pigtail	PC1900- IE-x/OE-RJ45 (PC2415-x/PC2415-1Y)	Remarks
V_+	1	Red	Power supply
GND	2	Blue	Reference ground
Laser on/off +	7	Black (gray)	Switching inputs
Laser on/off -	8	Violet (pink)	

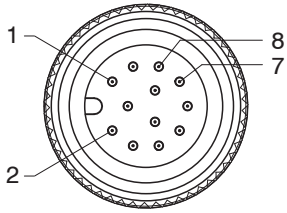

12-pin plug-in connector, M12, pin side of pigtail cable connector

Tab. 5.6: Pigtail connections on the sensor or open ends, PC1900- IE-x/OE-RJ45 or PC2415-x/PC2415-1Y

5.3.5 Supply voltage

The sensor is supplied via the PC1900-IE-x/OE-RJ45 or PC2415-x/PC2415-1/Y cable

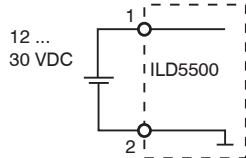
EtherCAT without PoE			
Sensor Pin	Color	Power supply	
1	Red	V_+	
2	Blue	GND	

As an alternative to PoE, the sensor can be supplied with the optional PS2020 power supply unit.

Voltage supply only for measuring devices, not to be used for drives or similar sources of impulse interference at the same time. MICRO-EPSILON recommends using the optionally available PS2020 power supply unit for the sensor.

- ▶ Only turn on the power supply after wiring has been completed.
- ▶ Connect the inputs Pin 1 and Pin 2 at the sensor with a 24V power supply.

EtherCAT with PoE	
Sensor supply is via a PoE-capable switch. Phantom powering (PoE) is possible via the - PC1900-IE-x/RJ45	

5.3.6 Turning on the laser

The measuring laser on the sensor is switched on via a software command or a switching input. This is advantageous when switching off the sensor for maintenance or similar tasks Response time: after the laser is switched on, the sensor needs depending on the measuring rate five cycles to send correct measured data.

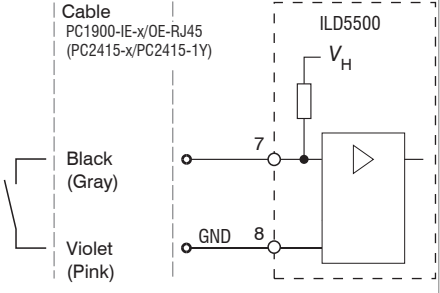
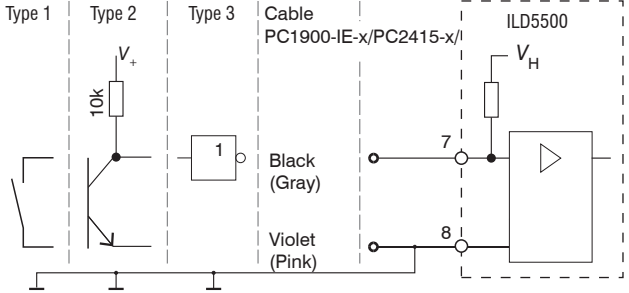
Laser on/off via software, supply via PoE	Laser on/off via hardware, supply via PoE	Laser on/off via hardware, supply without PoE
The measuring laser on the sensor is activated via a software command.	The measuring laser on the sensor is activated via a switch or equivalent.	A switching transistor with an open collector (e.g. in an optocoupler), a relay contact or a digital TTL or HTL signal are suitable for switching.
Using the PC1900-IE-x/RJ45 cable.	Using the PC1900-IE-x/OE-RJ45 or PC2415-x/PC2415-1Y cable.	Using the PC1900-IE-x/OE-RJ45 or PC2415-x/PC2415-1Y cable.
		
		<p>The inputs are not electrically separated. 24V logic (HTL): Low ≤ 3 V; High ≥ 8 V (max 30 V), Internal pull-up resistor, an open input is detected as High. Max. switching frequency 10 Hz The ground of the logic circuit must be galvanically connected to "Laser on/off -".</p>
<p>An external resistor is not required for current limitation. For permanent "Laser on", the black and violet or gray and pink wires must be connected.</p>		

5.3.7 Plug connection, supply and output cables

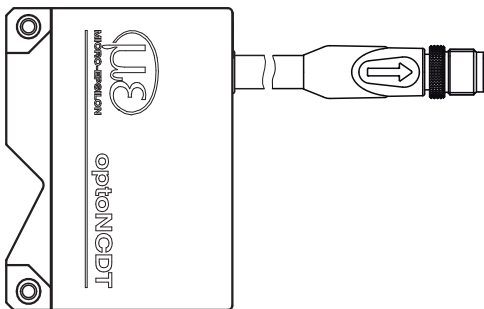

Fig. 5.6: ILD5500-x with pigtail

- ▶ Do not bend the sensor cable more tightly than 30 mm (fixed installation) or 75 mm(permanently flexible).

i The firmly connected sensor cable is drag-chain suitable.
 Unused open cable ends must be insulated to protect against short circuits or sensor malfunctions.

MICRO-EPSILON recommends the use of the drag-chain compatible standard connection cable PC1900-IE from the optional accessories

- ▶ Fasten the plug connection of the cable plug and socket when using a drag-chain compatible PC1900-IE sensor cable.
- ▶ Avoid excessive pull on the cables. If a cable of over 5m in length is used and it hangs vertically without being secured, make sure that some form of strain relief is provided close to the connector.
- ▶ Do not twist a mated connection.
- ▶ Connect the cable shield to the potential equalization (PE, protective earth conductor) on the evaluator (control cabinet, PC housing) and avoid ground loops.
- ▶ Never lay signal lines next to or together with power cables or pulse-loaded cables (e.g., for drives or solenoid valves) in a single bundle or duct. Always use separate ducts.

6 Operation

6.1 Getting ready for operation

- ▶ Mount the sensor according to the installation instructions., [see Chap. 5](#)
- ▶ Connect the sensor to downstream display or monitoring units and the power supply.

The laser diode in the sensor is only activated

- due to software command or
- when the black and violet wires of the PC1900-IE-x are connected

Once the power supply has been switched on, the sensor runs through an initialization sequence. Already within the first second a connection to the sensor can be established and the measurement can be started.

During the first three seconds, an internal function check in the sensor is indicated by the Status LED, which lights up in the colors red, yellow and green one after another.

Initialization takes a maximum of 3 seconds. Within this period, only the RESET or the BOOTLOADER command is executed via the `Select` button.

The sensor requires a warm-up time of typically 30 minutes for reproducible measurements.

If the `State` LED is off, the laser light source is switched off.

If all LEDs are off, no power is being supplied.

6.2 Operation via web interface

6.2.1 General

The sensors start with the last stored operating mode. EtherCAT is standard. Access via Ethernet is possible in Ethernet setup mode. Alternatively, Ethernet data traffic can also be tunneled via EtherCAT (EoE).

A web server is implemented in the sensor; the web interface displays, among other things, the current settings of the sensor. Operation is only possible while there is an Ethernet connection to the sensor.

- ▶ Choose between the two following operation modes.

Operation mode 1: **Ethernet setup mode**

- ▶ Switch to the Ethernet setup mode.

Details can be found in `section Switch between EtherCAT and Ethernet setup mode`.

The standard IP address is 169.254.168.150. Note: As IP setting of the network card to which the sensor is connected, we recommend a static configuration with 169.254.168.1 as IP address and the subnet mask 255.255.0.0.

Operation mode 2: **Ethernet over EtherCAT (EoE)**

Parallel to the EtherCAT operation you can adjust the sensor.

- ▶ `Virtual Ethernet Port` is a name in TwinCAT.
- ▶ Assign a MAC address and an IP address to the slave.
- ▶ Start your web browser and type the IP address of the sensor into the address bar. Besides the web page, you can also install a new firmware via Ethernet using the firmware update tool.

6.3 Access via web interface

- ▶ Start the sensor's web interface.

Interactive web pages for configuring the sensor now appear in the web browser. The sensor is active and provides measurement values.

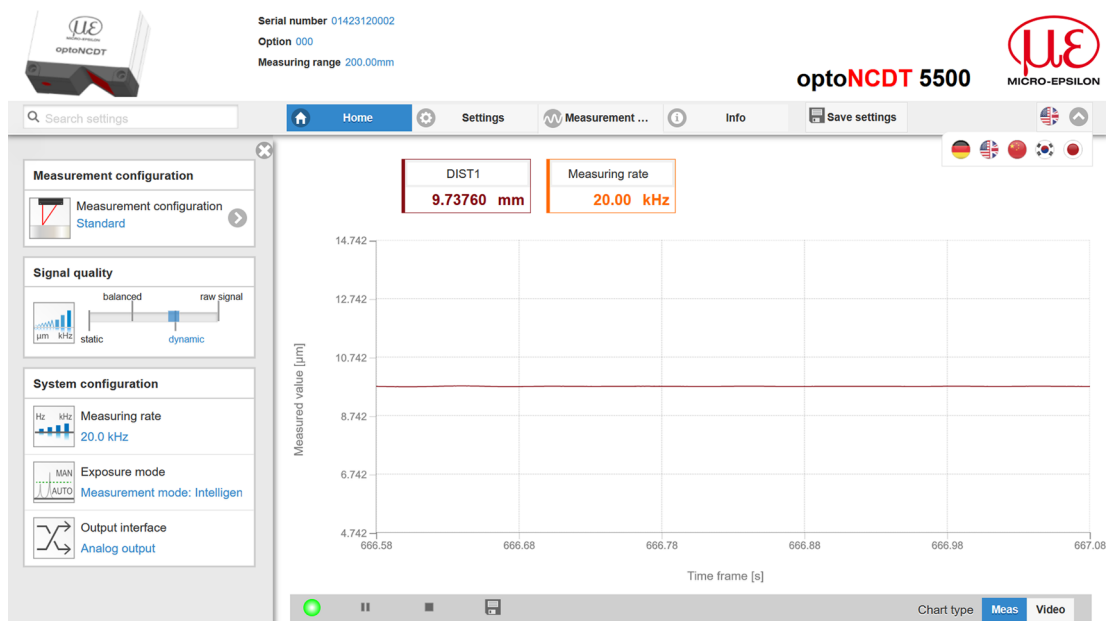

Fig. 6.1: First page after web interface has been accessed

The horizontal navigation contains the following functions:

- The search function enables time-saving access to functions and parameters.
- Home. The web interface starts automatically in this view with Measurement chart, Measurement configuration and Signal quality.
- Settings. This menu contains all sensor parameters.
- Measurement chart. Measurement chart with digital display or video signal display.
- Info. Contains information about the sensor, including serial number, software version and an overview of all sensor parameters.
- Web interface language selection

The appearance of the web pages may change depending on the functions. Dynamic help texts with excerpts from the operating instructions support you in configuring the sensor.

- i Depending on the selected measuring rate and the PC used, measured values may be reduced dynamically in the display. That is, not all measured values are transmitted to the web interface for display and saving.

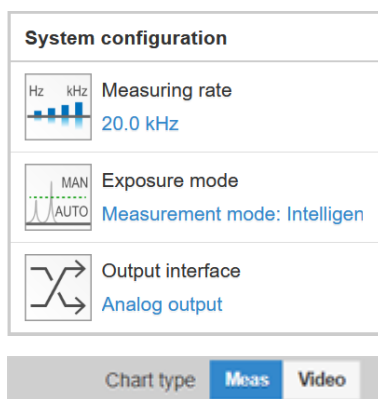

The System configuration section in the Home tab shows the current settings, including for the Measuring rate and Output interface in blue.

The Chart type section enables you to switch between the graphical presentation of a measurement value and the video signal.

6.4 Presets, setups, selection of measurement configuration

Definiton

- Preset: Manufacturer-specific program containing settings for common measuring tasks that cannot be overwritten.

- Setup: User-specific program containing the relevant settings for a measurement task.
- Initial setup at boot (sensor start): a favorite can be selected from the setups, which is automatically activated at sensor start. If no favorite is determined from the setups, the sensor activates the Standard preset at startup.

Upon delivery of the sensor from the factory

- the presets Standard, Multi-Surface and Light Penetration are possible
- no setups are available.

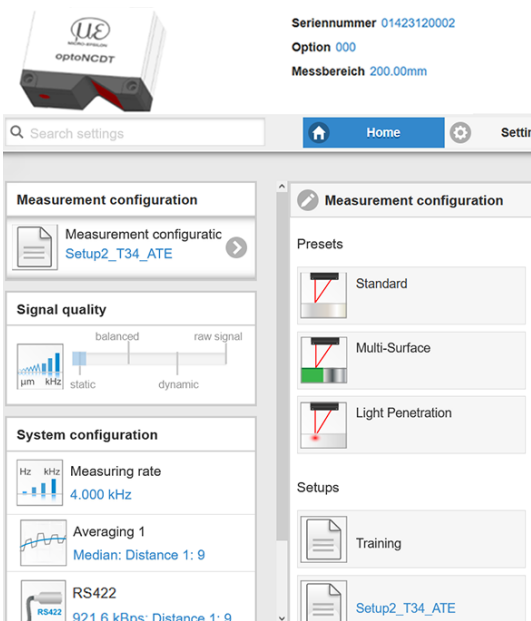

You can select a preset in the tab

- Home > Measurement configuration

You can select a setup in the tab

- Home > Measurement configuration
- Settings in the menu System settings > Load & Save > Saved measurement settings

A maximum of 8 setups can be permanently stored.

Tab. 6.1: Extract from the web interface, Home tab

For all presets, the averaging can be individually adapted to the measurement task via the Signal quality slider.

i If the sensor starts with a user-specific measurement setting (setup), the signal quality cannot be changed.

	Averaging	Description
	Balanced Median with 9 values + Moving with 64 values	In the Signal quality section you can switch between four predefined basic settings (static, balanced, dynamic and without raw signal). The reaction in the chart and system configuration is immediately visible.
	Raw signal, without averaging	
	Static Median with 9 values + Moving with 128 values	
	Dynamic Median with 9 values	

These presets enable quick startup of the respective measurement task. Selecting a preset which is suitable for the target surface activates a predefined configuration of settings that will produce the best results for the target material selected.

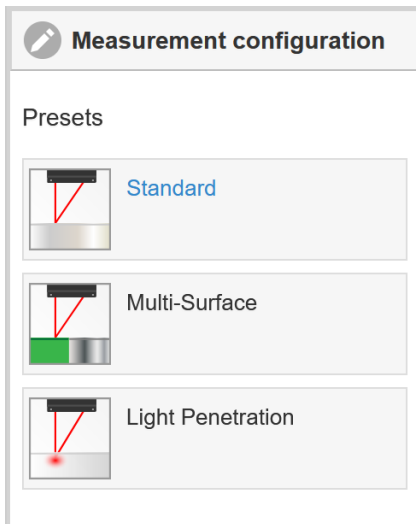

Selection of configuration

Standard	Ceramics, metals
Multi-Surface	PCBs, hybrid materials
Light Penetration	Plastics (Teflon, POM), materials with strong laser penetration depth

i After parameterization, store all settings permanently in a parameter set so that they are available again the next time the sensor is switched on. To do this, use the `Save settings` button.

6.5 Display of measurement values in the web browser

► Use the `Measurement chart` tab to display the measured values.

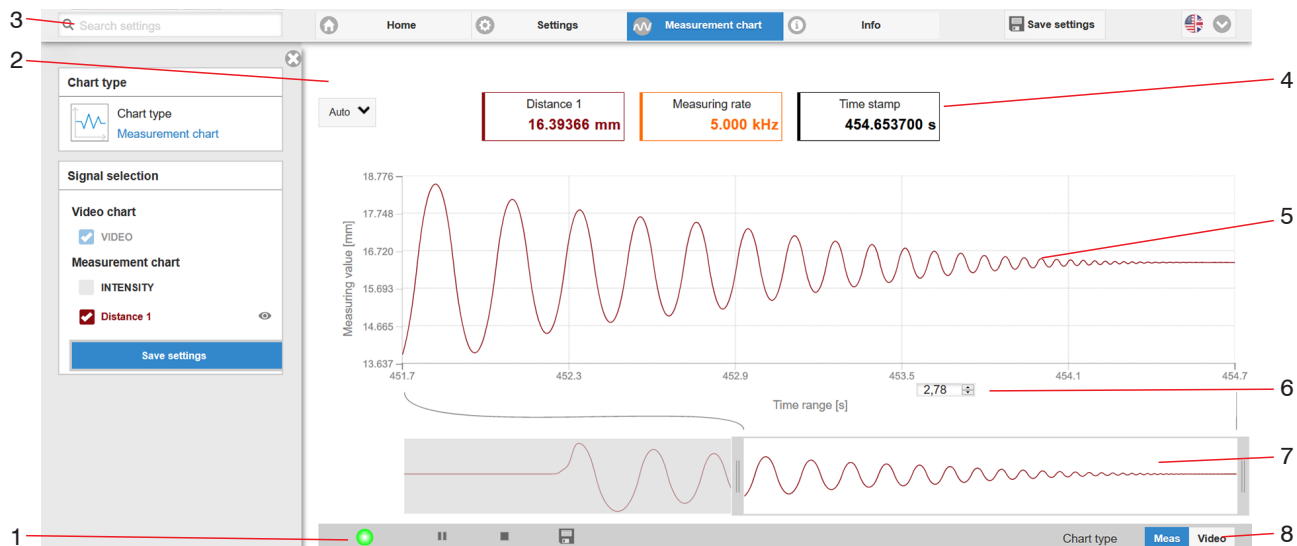

Fig. 6.2: Website Meas (distance measurement)

1 The LED visualizes the state of measured value transmission.

green Transmission of measured values in progress

yellow Waiting for data in trigger mode

gray Transmission of measured values stopped

The data query is controlled using the buttons `Play/Pause/Stop/Save` of the transmitted measured values. `Stop` stops the chart; data selection and the zoom function are still possible. `Pause` pauses the recording. `Save` opens the Windows selection dialog for the file name and storage location to save the last 10,000 values in a CSV file (separation using semicolon).

Click on the `Start` button to display the measurement results.

- 2 To scale the measurement value axis of the graph (y-axis), you can use `Auto` (= automatic scaling) or `Manual` (= manual scaling).
- 3 The search function permits time-saving access to functions and parameters.
- 4 The text boxes above the graph display the current values for distance, exposure time, current measuring rate, display rate, and timestamp.
- 5 Mouseover function. When the chart has been stopped and you move the mouse over the graph, points on the curve are marked with a circle and the associated values are displayed in the text boxes above the graph. Peak intensity is also updated.
- 6 The x-axis can be scaled in the input field under the time axis.
- 7 Scaling the x-axis: During an ongoing measurement, you can use the left-hand slider to enlarge the entire signal (zoom). When the chart has been stopped, the right-hand slider can also be used. You can also move the zoom window with the mouse in the center of the zoom window (four-sided arrow).
- 8 Select a chart type: measurement values or video signal

6.6 Video signal display in the web browser

- Display the video signal using the `Video` function in the `Chart type` section.

The graph displayed in the large chart area on the right represents the video signal and the receiving row. The video signal displayed in the chart area displays the intensity distribution of the pixels in the receiving row. The display covers the entire line, including the extended measuring range. Left 0 % (small distance) and right 100 % (large distance). The corresponding measured value is marked by a vertical line (peak marking).

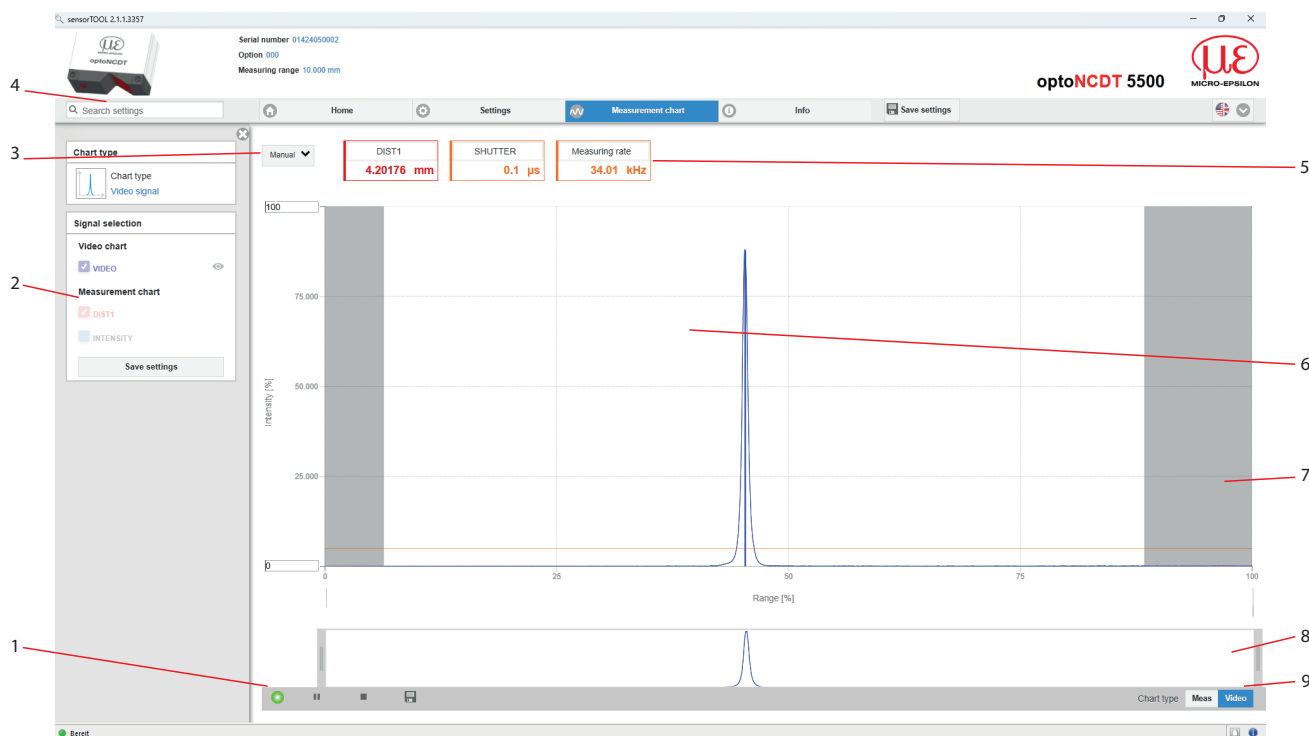

Fig. 6.3: Video signal web page

- 1 The LED visualizes the state of measured value transmission.
 green Transmission of measured values in progress
 yellow Waiting for data in trigger mode
 gray Transmission of measured values stopped
 The data query is controlled using the buttons `Play/Pause/Stop/Save` of the transmitted measured values `Stop` stops the chart; data selection and the zoom function are still possible. `Save` opens a Windows selection dialog for the file name and storage location to save the video signal in a CSV file.
 Click on the `Start` button to display the video signal.

- 2 In the left-hand window, the video curves to be displayed can be switched on or off during or after the measurement. Inactive curves are grayed out and can be added by clicking on the check mark. If you want to have displayed one single signal, click on its name.
 - Peak marking (vertical blue line), corresponds to the evaluated measurement value
 - Linearized measuring range (limited by gray hatching), not changeable
 - Masked range (limited by light blue hatching), changeable
- 3 For scaling the intensity axis (y-axis) of the graph, you can either select `Auto` (= Auto-scaling) or `Manual` (= manual setting).
- 4 The search function permits time-saving access to functions and parameters.

i ASCII commands to the sensor can also be entered directly in the search field.

- 5 The text boxes display the current values for distance, exposure time, current measuring rate, display rate and time stamp.
- 6 Mouseover function. When stopped, moving the mouse over the graph marks curve points with a circle symbol and displays the associated intensity. The corresponding x-position in % appears above the graphic field.
- 7 The linearized range lies between the gray shades in the chart and cannot be changed. Only peaks whose middles lie within this range can be calculated as a measured value. The masked area can be restricted if necessary and is then limited by an additional light blue shading on the right and left. The peaks remaining in the resulting range are used for the evaluation.
- 8 X axis scaling: The chart displayed above is zoomable with both sliders on the right and on the left side in the lower total signal. The overall signal can also be moved to the side using the mouse in the center of the zoom window (arrow cross).
- 9 Select a chart type: measurement values or video signal

The display shows how the adjustable measurement task (target material), peak selection and possible interfering signals due to reflections or similar affect the video signal. There is no linear relationship between the position of the peak in the video signal display and the output measured value.

6.7 Parameter setting via EtherCAT

EtherCAT includes a mechanism for parameterizing the EtherCAT slaves. Service Data Objects (SDO) are defined for this purpose, which contain the parameters for configuring the sensor. For details about reading and changing SDO, please refer to the description of your EtherCAT master. An overview of the available SDOs can be found in the appendix, see [Chap. 19.3.2](#).

6.8 Time response, measurement value flow

The sensor requires 4 cycles to measure and process without triggering:

The cycle time is 50 μ s at a maximum measuring rate of 20 kHz. The measured value N is available at the output after five cycles. The delay time between detection and start of output is therefore at least 250 μ s. As the cycles are processed in parallel, the next measured value (N+1) is output after another cycle.

i At a measuring rate of 20 kHz, the cycle time is 50 μ s. Accordingly, the delay time between detection and the start of output is at least 250 μ s.

Triggering always occurs at the beginning and not at the end of the 5 cycles. If the trigger timing is unfavorable, a previous value can be selected (jitter).

7 Setting sensor parameters, web interface

7.1 Preliminary remarks concerning the setting options

There are two ways to parameterize the optoNCDT 5500:

- Using the web browser and sensor web interface,
- using EtherCAT via the SDO, [see Chap. 19.3.2](#)

i If you do not permanently save the parameter set in the sensor, the settings are lost when the sensor is turned off. If supported by the EtherCAT master, values for the SDO objects can be permanently stored in the EtherCAT master and transferred to the sensor when the system is started.

7.2 Overview of parameters

You can set or change the following parameters in the optoNCDT 5500, [see Settings tab](#).

Data acquisition	Field linearization, Measuring rate, Evaluation range (ROI), Exposure mode, Peak selection, Reset counter
Signal processing	Measurement value averaging
Postprocessing	Zeroing/Mastering, Statistics
System settings	Unit on the web interface, Load & Save, Import & Export, Access authorization, Reset sensor (factory settings), Laserpower, Boot mode

7.3 Laser power

- In the [Settings tab](#), switch to the [System settings menu](#).

Laser power	<i>Full</i>	<i>Full power for standard surfaces</i>	The laser light source is active only when Pin 7 is connected to Pin 8, see Chap. 5.3.6
	<i>Medium</i>	<i>Optimized power for strongly reflecting surfaces and small measuring ranges</i>	
	<i>Reduced</i>	<i>Minimum power for service purposes</i>	
	<i>Off</i>	<i>Laser is off</i>	
Synchronization with EtherCAT	with	If multiple sensors are to measure the same target at the same time, the sensors can be synchronized with one another. You can find more details on this in the Distributed Clocks , see Chap. 19.4.5.2 section.	

i Pay attention to the signal intensity when switching the laser power. The best possible results are achieved with a signal intensity of 25 ... 50 %

7.4 Data acquisition

7.4.1 Preliminary remarks

- In the [Settings tab](#), switch to the [Data acquisition menu](#).

According to the previous setting in the Diagram type area, a diagram is displayed in the right part of the display. The diagram is active and all settings become immediately visible. Notes on the chosen settings are displayed below.

In the left area, the menus for the [Data acquisition](#) are displayed.

7.4.2 Measuring rate

The measuring rate indicates the number of measurements per second.

- ▶ Select the required measuring rate.

Measuring rate	free measuring rate	value	Use a high measuring rate for bright and mat measuring objects. Use a low measuring rate for dark or shiny measuring objects (e.g. black painted surfaces) to improve the measurement result.
----------------	---------------------	-------	---

The lower the measuring rate, the longer the maximum exposure time can be - always depending on the nature of the object being measured. The measuring rate is factory set to 4 kHz.

7.4.3 Measurement configuration

Details can be found in the operating instructions of the web interface, see Chap. 6.4

7.4.4 Measurement task

Details can be found in the operation of the web interface, see Chap. 6.4

7.4.5 Masking the region of interest, ROI

Masking limits the region of interest (ROI) for the distance calculation in the video signal. This function is used in order to e.g. suppress interfering reflections or ambient light.

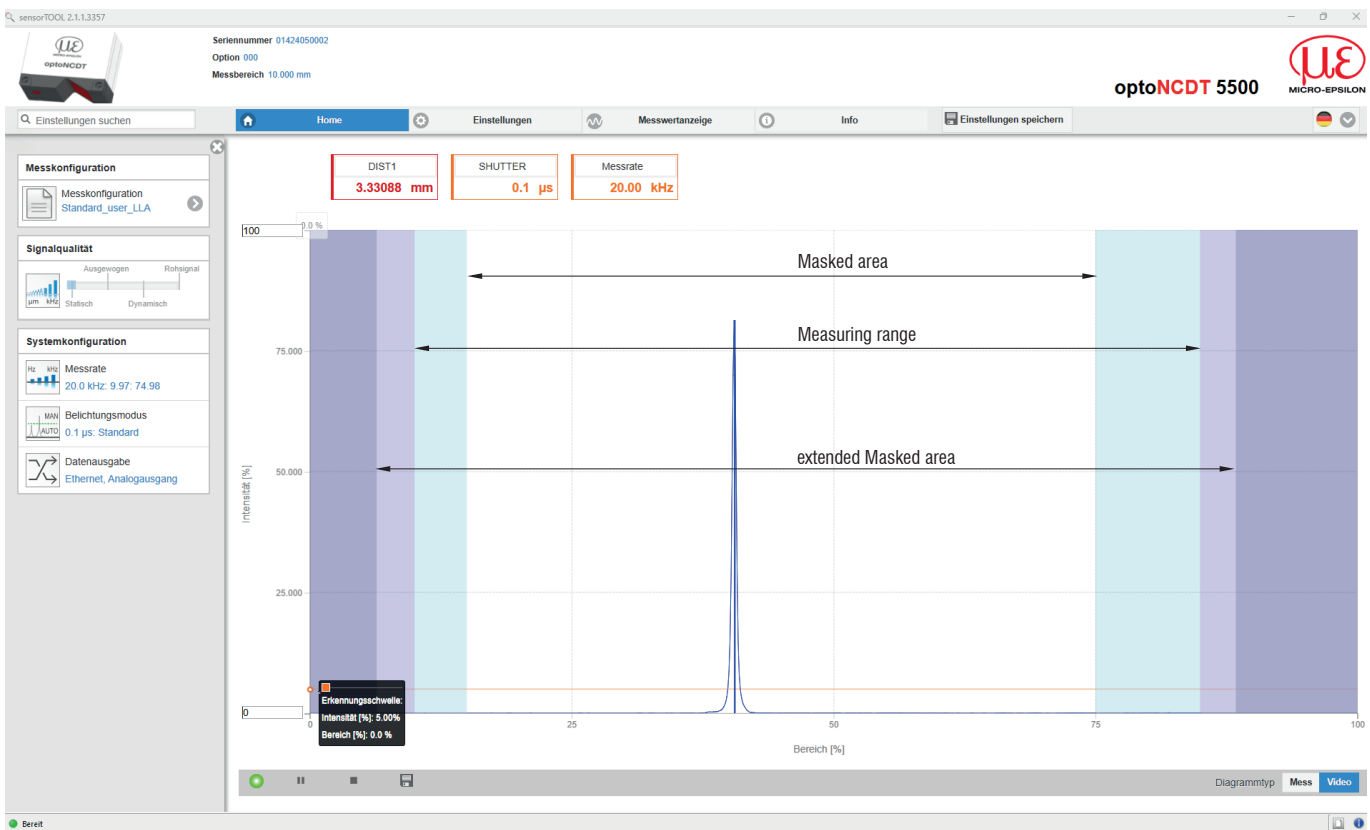
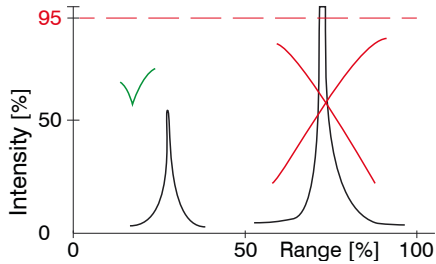

Fig. 7.1: ROI Standard

The exposure control optimizes the peaks in the region of interest. Therefore, small peaks can be optimally adjusted when a high interference peak is outside the region of interest.

7.4.6 Exposure mode

Exposure mode	Measurement mode	Standard / Background suppression		 <p>The sensor automatically determines the ideal exposure times and adjusts the intensity to around 50 to 60 %. The integrated, intelligent control algorithm is particularly advantageous for measurements of moving objects or material transitions.</p>
	Manual mode	Exposure time in μ s	value	

7.4.7 Peak selection

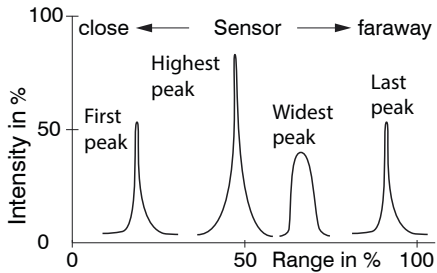
Peak selection	Highest peak / First peak / Last peak / Widest peak	<p>Defines which signal in the array signal is used for the evaluation.</p> <p>First peak: Nearest peak to sensor.</p> <p>Highest peak: Standard, peak with the highest intensity.</p> <p>Last peak: Peak furthest away from sensor. Widest peak: Peak with largest area.</p>	
----------------	---	---	---

If a measuring object contains multiple transparent layers, a correct measurement result is determined only for the first peak.

7.5 Signal processing

7.5.1 Preliminary remarks

- In the **Settings** tab, switch to the **Signal processing** menu.

According to the previous setting in the **Diagram type** area, a diagram is displayed in the right part of the display. The diagram is active and all settings become immediately visible. Notes on the chosen settings are displayed below.

In the left area, the menus for the **Signal processing** are displayed.

7.5.2 Averaging

7.5.2.1 General

It is recommended to use averaging of the measured values for statistical measurements or slowly changing measurement values.

The **Averaging 1** function is executed before the **Averaging 10** function.

Averaging	<i>No averaging</i>		<i>Measurements are not averaged.</i>
	<i>Moving N values</i>	2 ... 4096	<i>Value Value</i>
	<i>Recursive N values</i>	2 ... 32767	<i>Value</i>
	<i>Median N values</i>	3 / 5 / 7 / 9	<i>Value</i>

Specification of the averaging type. The averaging number N indicates how many consecutive measured values are averaged in the sensor.

Measurement averaging is performed after the distance values have been calculated, and before they are issued through the relevant interfaces.

Measurement averaging

- improves the resolution,
- allows the masking of individual interference points, or
- “smooths” the measurement result.

Linearity is not affected by averaging.

The average values are continuously recalculated with each measurement. The desired averaging depth is only achieved after the number of recorded measurement values corresponds at least to the averaging depth.

Note The defined type of average value and the averaging number must be stored in the sensor to ensure they are hold after it is switched off.

Averaging has no effect on the measuring rate or data rate in case of digital measurement value output. The averaging numbers can also be programmed via the digital interfaces. The sensor is delivered with “Median 9” as factory settings, i.e. median averaging over 9 measurement values.

Depending on the type of average and the number of averaged values, different transition response times result thereof

7.5.2.2 Moving mean

The definable number N for successive measurements (window width) is used to calculate the arithmetic average M_{mov} according to the following formula:

$$M_{\text{mov}} = \frac{\sum_{k=1}^N MV(k)}{N}$$

MV	Measurement value
N	Averaging number
k	Continuous index (in the window)
M_{mov}	Average value or output value

Methods:

Each new measured value is added, and the first (oldest) value is removed from the averaging (from the window). This produces short settling times in case of measurement jumps.

Example: $N = 4$

... 0, 1, <u>2, 2, 1, 3</u>	... 1, 2, <u>2, 1, 3, 4</u>	Measured values
↓	↓	
$\frac{2, 2, 1, 3}{4} = M_{\text{mov}}(n)$	$\frac{2, 1, 3, 4}{4} = M_{\text{mov}}(n+1)$	Output value

Special features:

All values are permitted for the averaging number N in the sensor's moving average. The range of values for the averaging number N is 1 ... 4096.

7.5.2.3 Recursive average

Formula:

$$M_{\text{rek}}(n) = \frac{MW_{(n)} + (N-2) \times M_{\text{rek}}(n-1)}{N}$$

N = Averaging number, $N = 2 \dots 32767$

n = Measured value index

MV = Measurement value

M_{rec} = average or output value

Methods:

Each new measured value $MV_{(n)}$ is weighted and added to the sum of the previous average values $M_{\text{rec}}(n-1)$.

Please note:

Recursive averaging allows for very strong smoothing of the measurements, however it requires long response times for measurement jumps. The recursive average value shows low-pass behavior. The range of values for the averaging number N is 2 .. 32767.

7.5.2.4 Median

A median value is formed from a preselected number of measured values.

Methods:

The incoming measured values (3, 5, 7 or 9 measurement values) are also sorted again after each measurement. The middle value is then output as the median. 3, 5, 7 or 9 measured values are taken into account for the calculation of the median, i.e. there is no median 1.

Special features:

This averaging type suppresses individual interference pulses. However, smoothing of the measurement curves is not very strong.

Example: $N = 5$

... 0 1 2 4 5 1 3 → Sorted measurements: 1 2 **3** 4 5 Median_(n) = 3

... 1 2 4 5 1 3 5 → Sorted measurements: 1 3 **4** 5 5 Median_(n+1) = 4

Tab. 7.1: Example median $N=5$

7.6 Postprocessing

7.6.1 Zeroing, mastering

Use zeroing and mastering to define a nominal value within the measuring range. This shifts the output range. This feature can be useful, for example, when several sensors perform simultaneous measurements in thickness and planarity measurements or during sensor replacement.

Mastering is used to compensate for mechanical tolerances in the sensor measurement setup or to correct chronological (thermal) changes to the measuring system. The master value, also called calibration value, is defined as the nominal value.

i Mastering or Zeroing requires a target object to be present in the measuring range. Mastering or Zeroing affects the digital output and the display equally.

The screenshot shows the 'Zeroing/Mastering' section of the web interface. It includes a dropdown menu for 'Master signal' (currently set to 'Distance 1'), a text input for 'Master value in mm' (set to '2'), and buttons for 'Apply master signal', 'Delete master signal', 'Select master signal' (set to 'All'), 'Activate master value', and 'Reset master value'. Red lines with numbers 1 through 6 point to these elements: 1 points to the 'Master signal' dropdown, 2 to the 'Master value in mm' input, 3 to the 'Apply master signal' button, 4 to the 'Select master signal' dropdown, 5 to the 'Activate master value' button, and 6 to the 'Reset master value' button.

- 1 Selecting a signal for the function, assigning master value.
- 2 Saves master value in volatile memory^[15].
- 3 Deletes master value in volatile memory.
- 4 Selection of a certain signal or function
- 5 Starting the function
- 6 Ending the function, returning to absolute measurement.

Mastering / zeroing sequence:

- ▶ Bring the measuring object and sensor into the desired relative position
- ▶ Send the Master command (EtherCAT) or click the `Activate master value` button. After setting the master, the controller will issue new readings that relate to the master value. By resetting with the `Reset master value` button, the status before mastering is restored.

7.6.2 Statistics

The measuring system derives the following statistical values from the result of the measurement:

- Minimum,
- Maximum and
- Peak-to-Peak.

Statistical values are calculated from measured values within the region of interest. The region of interest is updated with each new measurement value. The statistical values are displayed via the web interface in the `Postprocessing` section, or are output via the interfaces.

The statistical values are not channel-specific. The controller can manage up to 10 statistic signals. These 10 signals can be applied to any internally determined value, including calculated values.

7.7 System settings

7.7.1 General

After programming, all settings must be saved permanently under a parameter set so that they are available again the next time the sensor is switched on.

7.7.2 Web interface unit

The web interface supports units in millimeters (mm) and inches in the display of the measurement results.

7.7.3 Language in the web interface

The web interface is available in German and English, among other languages. Switch the language in the menu bar.



[15] The `Save settings` function permanently saves the master value to a setup.

7.7.4 Loading, saving

All the sensor settings can be saved permanently in user programs, which are known as setups.

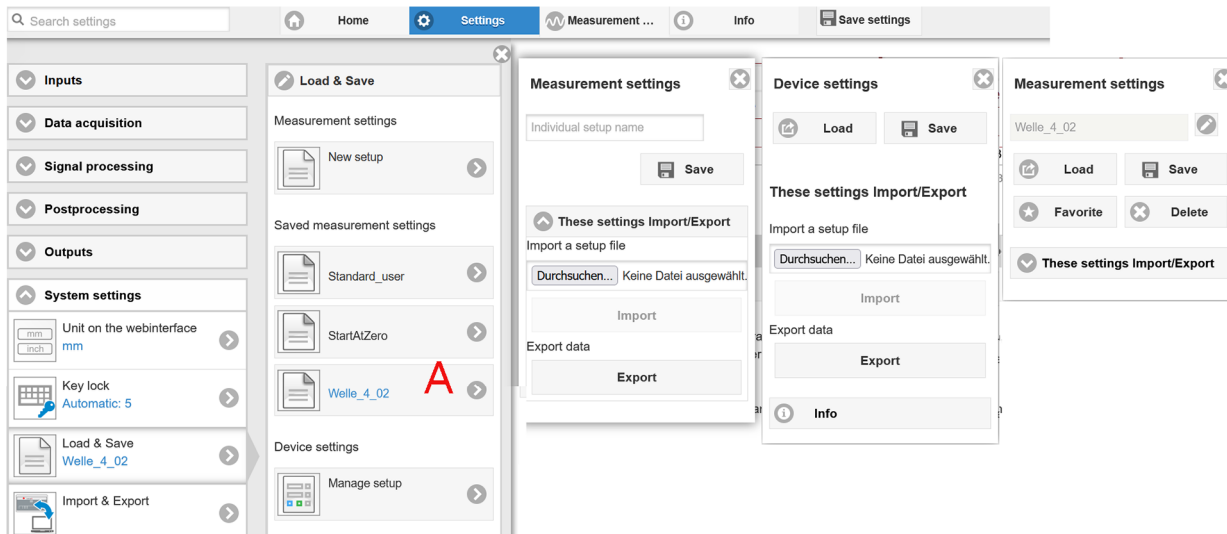



Fig. 7.2: Managing user programs

Managing setup in the sensor, options and procedure - see example "A"			
Saving the settings	Activating existing setup	Saving changes in the active setup	Determining setup after booting
New setup menu	Load & Save menu	Menu bar	Load & Save menu
Enter the name for the setup in the Individual setup name field, e.g. Shaft 4_02 and confirm the entry with the Save button.	The desired setup can be found in section A. Left-click on the setup. The following dialog opens: Measurement settings. Click on the Load button.	Click on the button 	Left-click on the setup. The following dialog opens: Measurement settings. Click on the Favorite button.

Exchange setup with PC/notebook, options	
Saving setup on PC	Loading setup from PC
Load & Save menu	Load & Save menu
Left-click on the setup. The Measurement settings dialog opens. Click on the Export button.	Left-click on New setup. The Measurement settings dialog opens. Click These settings Import/Export. A Windows dialog for file selection opens. Select the desired file and click the Open button. Click on the Import button.

7.7.5 Import, export

A parameter set includes the current settings, setup(s) and the initial setup when booting the sensor.

The Import & Export menu allows you to easily exchange parameter sets with a PC/notebook.

Exchange of parameter sets with PC/notebook, possibilities	
Storing parameter set on PC	Loading parameter set from PC
<p>Import & Export menu</p> <p>Click on the button <code>Parameter set</code> with the left mouse button. The <code>Choose export data</code> dialog opens. Compose a parameter set by selecting/deselecting the checkboxes. Click on the <code>Transmit file</code> button. A Windows dialog for data transfer opens. The operating system automatically stores the parameter set in the <code>Downloads</code> area. The file name for the adjacent example is therefore <code>\ Downloads\ILD5500_BA-SICSETTINGS_MEASSETTINGS_... .JSON></code> Open the download via the open menu window by clicking on <code>Open file</code>.</p>	<p>Import & Export menu</p> <p>Click the <code>Select file</code> button. A Windows dialog for file selection opens. Select the desired file and click on the <code>Open</code> button. The <code>Choose import data</code> dialog opens. Determine the operations to be performed by selecting/deselecting the checkboxes. Click on the <code>Transmit file</code> button.</p>

Parameter set for import

Settings

`Setup_Beispiel_A`

Reset sensor

Clear flash sections in the sensor before importing

`Settings`

`Initial setup at booting`

`Device settings`

Options during import

`Overwrite existing setups (with the same name)`

`Apply settings of the imported initial setup`

`Transmit parameter set`

In order to avoid that an already existing setup is overwritten unintentionally during import, an automatic security request is carried out (see adjacent figure).

Options during import:

`Overwrite existing setups (with the same name)`

`Apply settings of the imported boot setup`

7.7.6 Access authorization

Assigning passwords prevents unauthorized changes to sensor settings. The password protection is not activated in the delivery condition. The sensor operates at user level `Professional`. After the sensor has been configured, you should enable password protection. The standard password for the expert level is `000`.

i A software update will not change the default password or a user-defined password. The `Professional` password is independent of the setup and is therefore not loaded or saved together with the setup.

Users have the following functions available:

Action	User	Professional
Password required	no	yes
Read inputs, signal processing, outputs, system settings	yes	yes
Change inputs, signal processing, outputs, system settings	no	yes
Change password	no	yes
Toggling between measurement chart and video signal	no	yes
Scale graphs	yes	yes
Restore factory settings	no	yes

Tab. 7.2: Rights in the user hierarchy

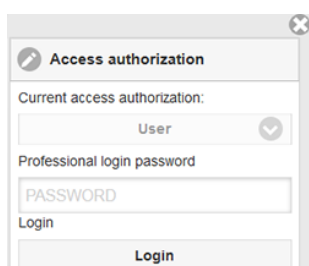

Enter the default password `000` or a user-defined password in the `Password` field and confirm your entry with `Login`.
 You can switch to the `User Operator` level by clicking on the `Logout` button.

Fig. 7.3: Switch to user level `Professional`

User management allows you to assign a user-defined password in the operating mode `Professional`.

Password	<i>Value</i>	<i>All passwords are case-sensitive; numbers are allowed. Special characters are not permitted. The maximum length is limited to 31 characters.</i>
User level on re-start	<i>User / Professional</i>	<i>Defines the user level that is enabled when the sensor starts the next time. Micro-Epsilon recommends the selection <code>Operator</code>.</i>

After the sensor has been configured, you should enable password protection. Please write down the password for later use.

7.7.7 Reset sensor

Reset sensor	Measurement settings	<i>Button</i>	<i>Deletes the settings for measuring rate, trigger, region of interest, peak selection, error handling, averaging, zeroing/mastering, data reduction and the setups. Loads the 1st preset.</i>
	Device settings	<i>Button</i>	<i>Deletes the baud rate, language, unit, key lock and echo mode settings and loads the default parameters.</i>
	Reset all	<i>Button</i>	<i>Deletes the settings for the sensor, the measurement settings, the access authorization, password and the setups. Loads the 1st preset.</i>
	Reboot controller	<i>Button</i>	<i>Reboots the sensor with the settings from the favorites setup, see Chap. 7.7.4.</i>

8 Industrial Ethernet data output

The output values from all internally determined values and the calculated values from the calculation modules are output in a fixed sequence.

Signal	Minimum	Maximum	Scaling/ Video signal	Unit
VIDEO (1024 x 16Bit)	0	4095	Value / 4096 * 100	%
ENCODER1	0	UNIT32_MAX	Value	Encoder ticks
SHUTTER	0	65536	Value / 10	µs
MEASRATE	250	150000	Value / 1000	kHz
TIMESTAMP	0	UINT32_MAX	Value / 10	µs
COUNTER	0	UINT32_MAX	Value	
STATE	0	UINT32_MAX	Bit 2: No peak found Bit 5: Distance before SMR (extended) Bit 6: Distance after EMR (extended) Bit 15: Measurement value is triggered Bit 16, 17: Status LED 00 – off 01 – red 10 – green 11 – yellow	
UNLIN	0	262143	Value / 256	Pixels
INTENSITY	0	4095	Value / 4096 * 100	%
DIST1	INT32_MIN	0x7ffffeff	Value / 1000000	mm
TRIGGEREVENTCOUNTER	0	UINT32_MAX	Value	
TRIGGERVALUECOUNTER	0	UINT32_MAX	Value	
TEMPERATURE	-127750	127750	Value / 1000	°C
*_MIN	INT32_MIN	0x7ffffeff	identical DIST1	mm
*_PEAK	INT32_MIN	0x7ffffeff	identical DIST1	mm
*_MAX	INT32_MIN	0x7ffffeff	identical DIST1	mm

Tab. 8.1: Output values Industrial Ethernet

value	Description
0x7FFFFFF04	No peak is present
0x7FFFFFF05	Peak is before the measuring range (MR)
0x7FFFFFF06	Peak is after the measuring range (MR)
0x7FFFFFF08	Measurement value cannot be evaluated
0x7FFFFFF09	Peak is too wide
0x7FFFFFF0A	Laser is off

Tab. 8.2: Industrial Ethernet status information

9 EtherCAT

9.1 Preliminary remarks

The sensor starts with the last stored operating mode. Standard is EtherCAT®. The Ethernet setup mode, like EoE, enables easy programming of a sensor, [see Chap. 6.3](#), [see Chap. 7](#).

9.2 Saving the settings, continuing EtherCAT® mode

- ▶ Go to Settings > System settings > Load & Save or click the Save settings button, [see Chap. 7.7.4](#)

The sensor now also saves the settings to the SD objects for use in EtherCAT® mode.

- ▶ Go to Settings > System settings > Boot mode. Select the entry Industrial Ethernet (EtherCAT®).

The screenshot displays the sensor's web interface. At the top, there is a search bar 'Einstellungen suchen', a 'Home' button, a settings icon, and a 'Messwertanzeige' button. The main content area is divided into two panels. The left panel, titled 'Systemeinstellungen', contains several settings: 'Einheit im Webinterface' (mm/inch), 'Laden & Speichern' (fgkm), 'Import & Export', 'Zugriffsberechtigung' (Experte), 'Sensor rücksetzen', and 'Bootmodus' (Wiederherstellung). The right panel, titled 'Bootmodus', shows a dropdown menu with 'Feldbus' and 'Wiederherstellung' (highlighted in blue). To the right of the settings is a measurement display showing 'Abstand 1' as 7.60453 mm. Below this is a graph of 'Messwert [mm]' over time, with a red line fluctuating around 7.60 mm. The x-axis ranges from 22.0 to 22.4. At the bottom, there is a 'Bootmodus' status bar with a green indicator light and control buttons.

The sensor disconnects from the browser and boots automatically with the EtherCAT® firmware. The boot process can take up to one minute.

Alternatively, you can return to the EtherCAT® operation via the Select button. Details can be found in section Switch between Ethernet Setup Mode and EtherCAT®, [see Chap. 18](#)

Continue working in your PLC environment.

10 Cleaning

We recommend cleaning the protective glass at regular intervals.

Do not expose yourself to unnecessary laser radiation.

- ▶ Switch off the sensor for cleaning and maintenance.

Dry cleaning

This can be accomplished with an anti-static lens brush or by blowing off the windows with dehumidified, clean, oil-free compressed air.

Wet cleaning

Use a clean, soft, lint-free cloth or lens cleaning paper and pure alcohol (isopropanol) to clean the protective screen.

NOTICE

- ▶ Never use commercially available glass cleaners or other cleaning agents.

11 Software support with MEDAQLib

MEDAQLib is a documented driver DLL. This allows you to integrate sensors from Micro-Epsilon in conjunction with a converter or interface module into existing or customer-specific PC software.

MEDAQLib

- ▶ contains a DLL that can be imported into C, C++, VB, Delphi and many other programs,
- ▶ takes care of data conversion for you,
- ▶ works regardless of the type of interface used,
- ▶ uses the same functions for communication (commands),
- ▶ provides a uniform transmission format for all Micro-Epsilon sensors.

For C/C++ programmers, an additional header file and a library file are integrated into MEDAQLib.

- You can download the MEDAQLib installation files to your computer via the link <https://www.micro-epsilon.com/link/software/medaqlib>.
- For further information on MEDAQLib, please visit <https://www.micro-epsilon.com/service/software-sensorintegration/medaqlib>.

12 Disclaimer

All components of the device have been checked and tested for functionality in the factory. However, should any defects occur despite careful quality control, these shall be reported immediately to Micro-Epsilon or to your distributor / retailer.

Micro-Epsilon undertakes no liability whatsoever for damage, loss or costs caused by or related in any way to the product, in particular consequential damage, e.g., due to

- non-observance of these instructions/this manual,
- improper use or improper handling (in particular due to improper installation, commissioning, operation and maintenance) of the product,
- repairs or modifications by third parties,
- the use of force or other handling by unqualified persons.

This limitation of liability also applies to defects resulting from normal wear and tear (e.g., to wearing parts) and in the event of non-compliance with the specified maintenance intervals (if applicable).

Micro-Epsilon is exclusively responsible for repairs. It is not permitted to make unauthorized structural and / or technical modifications or alterations to the product. In the interest of further development, Micro-Epsilon reserves the right to modify the design or the firmware.

In addition, the General Terms of Business of Micro-Epsilon shall apply, which can be accessed under Legal details | Micro-Epsilon <https://www.micro-epsilon.com/legal-details/>.

13 Service, repair

If the sensor or sensor cables are defective:

- If possible, save the current sensor settings in a parameter set to reload them into the sensor after the repair.
- Please send us the affected parts for repair or exchange.

If the cause of a fault cannot be clearly identified, please send the entire system including cables to:

MICRO-EPSILON
Optronic GmbH
Lessingstrasse 21
01465 Dresden-Langebrück / Germany

Tel: +49 (0) 35201 729-0
Fax: +49 (0) 35201 729 -90
optronic@micro-epsilon.de
www.micro-epsilon.com/contact/worldwide/
<https://www.micro-optronic.de/>

14 Decommissioning, disposal

In order to avoid the release of environmentally harmful substances and to ensure the reuse of valuable raw materials, we draw your attention to the following regulations and obligations:

- Remove all cables from the sensor and/or controller.
- Dispose of the sensor and/or the controller, its components and accessories, as well as the packaging materials in compliance with the applicable country-specific waste treatment and disposal regulations of the region of use.
- You are obliged to comply with all relevant national laws and regulations.

For Germany / the EU, the following (disposal) instructions apply in particular:

- Waste equipment marked with a crossed garbage can must not be disposed of with normal industrial waste (e.g. residual waste can or the yellow recycling bin) and must be disposed of separately. This avoids hazards to the environment due to incorrect disposal and ensures proper recycling of the old appliances.



- A list of national laws and contacts in the EU member states can be found at https://ec.europa.eu/environment/topics/waste-and-recycling/waste-electrical-and-electronic-equipment-weee_en. Here you can inform yourself about the respective national collection and return points.

- Old devices can also be returned for disposal to Micro-Epsilon at the address given in the legal details at <https://www.micro-epsilon.com/legal-details>.

- We would like to point out that you are responsible for deleting the measurement-specific and personal data on the old devices to be disposed of.

- Under the registration number WEEE-Reg.-Nr. DE28605721, we are registered at the foundation Elektro-Altgeräte Register, Nordostpark 72, 90411 Nuremberg, as a manufacturer of electrical and/or electronic equipment.

15 Optional accessories

PS2020



Power supply unit for DIN rail mounting
Input 230 VAC, output 24 VDC/2.5 A

PC2415-x

Cable extension with 12-pin M12 socket and 12-pin M12 plug for power supply, RS422 or encoder, Industrial Ethernet; suitable for drag chains, cable length x = 3 m, 6 m, 9 m or 15 m

PC1900-IE-x/RJ45



Interfaces and supply cable Length x = 3, 6 or 9 m 12-pin round socket and RJ45 plug for fieldbus connection

PC2415-1/Y

Supply/interface cable for IFD241x; with 12-pin M12 socket and open ends or RJ45 plug, cable length = 1 m

PC1900-IE-x/OE-RJ45

Extension of the sensor cable "Pigtail" 12-pin. M12 circular connector (coupling) RJ45 plug (Ethernet) + open ends (operating voltage, laser on/off) Various lengths (3; 6; 9m)

16 Factory settings

Measurement value averaging	Median, 9 values
Peak selection	Highest peak
Measuring range	100 % FSO: $I = 20$ mA, digital 163768
	0 % FSO: $I = 4$ mA, digital 98232

Language	German
Measuring rate	4 kHz

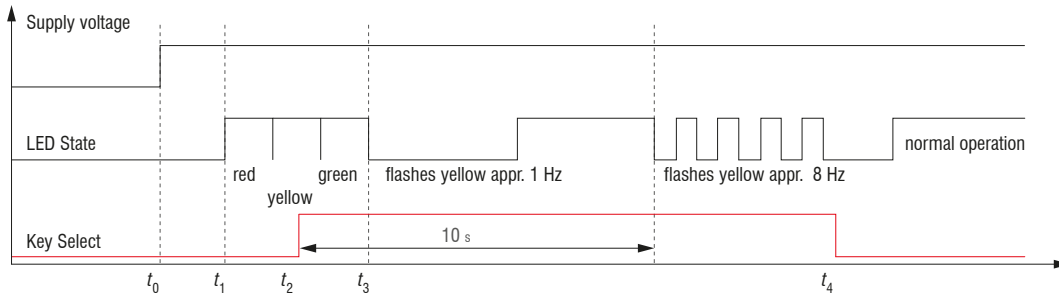

Fig. 16.1: Flowchart for starting a sensor with factory settings

- t_0 : Supply voltage is applied
- $t_1 \dots t_3$: Both LEDs signal the start sequence (red-yellow-green for 1 second each)
- t_2 : Select key is pressed during the start sequence ($t_1 \dots t_3$)
- t_4 : Select key is released while the State LED flashes yellow
 $\Delta t = t_4 - t_2$; Δt (keystroke duration) must be at least 10 seconds, max. 15 seconds

Resetting to factory setting:

- ▶ Press the `Select` key after having switched on the sensor while the two LEDs light up „red - yellow - green“.
- ▶ Hold the key pressed. After 10 seconds, the Status LED starts flashing quickly.
- ▶ If you release the key while it flashes quickly, the sensor is reset to factory settings.
- ▶ If you hold the key pressed for longer than 15 seconds, the sensor is not reset to factory settings.

If the `Select` key is kept pressed when switching on the sensor (or with a reset), the sensor switches to the Bootloader mode.

17 Switch between EtherCAT® and Ethernet setup mode

The sensor starts in the last stored operating mode. EtherCAT® is factory-set. Access via Ethernet is possible in Ethernet setup mode.

- Press and hold the Select button on the sensor before switching on the power supply on the sensor. Release the button again as soon as the State LED flashes yellow. Press the button again for approx. 10 to 15 seconds until the State LED flashes red.

Within the time $t_2 \dots t_3$, the red flashing starts at 8 Hz after 10 seconds. Release the key again after 15 seconds at the latest. When the Select button is released at the latest at time t_3 , the yellow State LED starts flashing at 8 Hz.

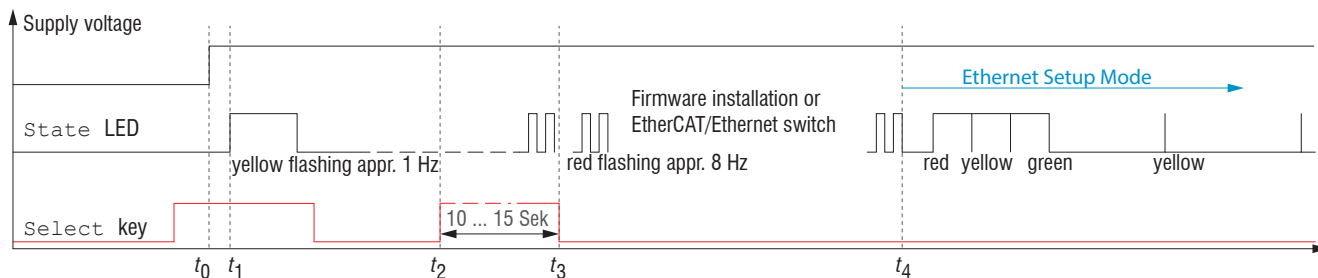

Fig. 17.1: Flowchart for starting a sensor in Ethernet setup mode

After completion of the firmware installation/switch, the sensor reboots at time t_4 .

- t_0 Supply voltage is applied
- t_1 The State LED starts flashing yellow, the Select button can be released
- t_2 Press the Select button again within 15 seconds ($t_2 - t_1$) and hold it down for another 10 ... 15 sec. ($t_3 - t_2$).
- $t_{3...4}$ The change from EtherCAT to Ethernet setup mode begins, duration max. 1 min.
- t_4 Sensor starts in Ethernet setup mode, the State LED lights up briefly at intervals of approx. 1 sec.

18 Switch between Ethernet Setup mode and EtherCAT®

The sensors start in the last stored operating mode. With the Select button, you can set the sensor to the operating mode EtherCAT®

- Press and hold the Select button on the sensor before switching on the power supply on the sensor. Release the button again as soon as the State LED flashes yellow. Press the button again for approx. 10 to 15 seconds until the State LED flashes red.

Within the time $t_2 \dots t_3$ the red flashing starts at 8 Hz after 10 seconds. Release the key again after 15 seconds at the latest. When the Select button is released at the latest at time t_3 , the yellow State LED starts flashing at 8 Hz.

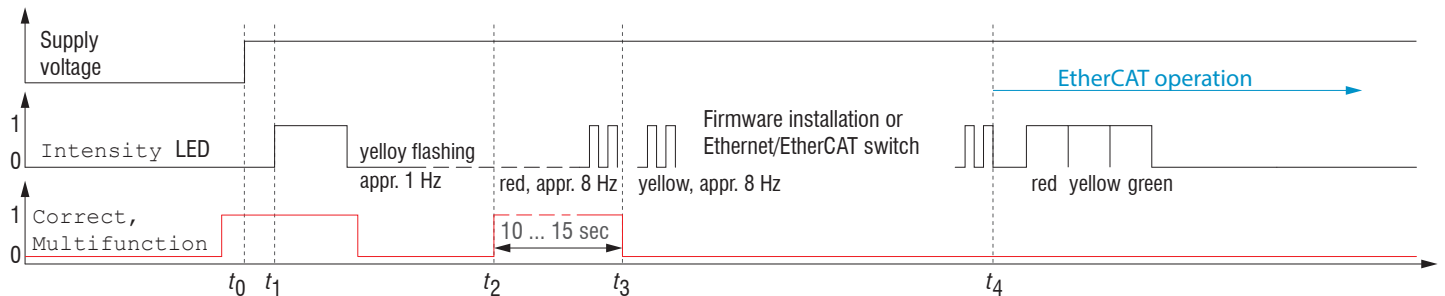

Fig. 18.1: Flowchart for starting a sensor in the EtherCAT® mode

After completion of the firmware installation/switch, the sensor reboots at time t_4

t_0	Supply voltage is applied
t_1	The State LED starts flashing yellow, the Select button can be released
t_2	Within 15 sec. ($t_2 - t_1$) press Select button again and hold for further 10 ... 15 sec. ($t_3 - t_2$)
$t_3 \dots t_4$	Switches from Ethernet Setup mode to EtherCAT, duration max. 1 min.
t_4	Sensor starts in EtherCAT mode

19 EtherCAT documentation

19.1 General

From an Ethernet point of view, EtherCAT® is an individual large Ethernet device that sends and receives Ethernet telegrams. An EtherCAT® system like this consists of an EtherCAT® master and up to 65535 EtherCAT® slaves.

Master and slaves communicate via standard Ethernet cabling. On-the-fly processing hardware is used in each slave. The incoming Ethernet frames are processed by the hardware directly. The relevant data is extracted from the frame or inserted. The frame is then sent on to the next EtherCAT® slave device. The fully processed frame is returned from the last slave device. Various protocols can be used at the application level. CANopen over EtherCAT® technology (CoE) is supported here. An object dictionary structure with service data objects (SDO) and process data objects (PDO) is used to manage the data in the CANopen protocol. Further information can be obtained from ®EtherCAT Technology Group (www.ethercat.org) or Beckhoff GmbH, (www.beckhoff.com).

19.2 Introduction

19.2.1 Structure of EtherCAT® frames

The data in Ethernet frames is transmitted with a special Ether type (0x88A4). An EtherCAT® frame like this consists of one or more EtherCAT® telegrams, each of which is addressed to individual slaves / storage areas. The telegrams are transmitted either directly in the data area of the Ethernet frame or in the data area of the UDP datagram. An EtherCAT® telegram consists of an EtherCAT® header, the data area and the work counter (WC). The work counter is incremented by each addressed EtherCAT® slave that has exchanged the associated data.

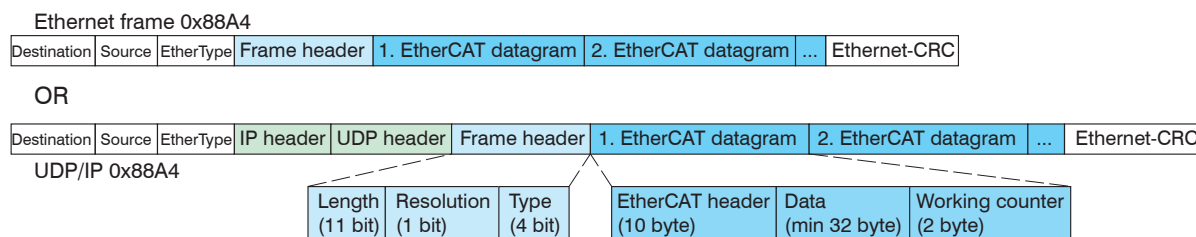

Fig. 19.1: Setup of EtherCAT® frames

19.2.2 EtherCAT® Services

In EtherCAT®, services are specified for reading and writing data in the physical memory within the slave hardware. The following EtherCAT® services are supported by the slave hardware:

- APRD (Autoincrement physical read, reading of a physical area with auto-increment addressing)
- APWR (Auto-Increment Physical Write, writing of a physical area with auto-increment addressing)
- APRW (Auto-Increment Physical Read Write, reading and writing of a physical area with auto-increment addressing)
- FPRD (Configured Address Read, reading of a physical area with fixed addressing)
- FPWR (Configured Address Write, writing of a physical area with fixed addressing)
- FPRW (Configured Address Read Write, reading and writing of a physical area with fixed addressing)
- BRD (Broadcast Read, broadcast-reading of a physical area for all slaves)
- BWR (Broadcast Write, broadcast-writing of a physical area for all slaves)
- LRD (Logical Read, reading of a logical storage area)
- LWR (Logical Write, writing of a logical storage area)
- LRW (Logical Read Write, reading and writing of a logical storage area)
- RMW (Auto-Increment Physical Read Multiple Write, reading of a physical area with auto-increment addressing, multiple writing)
- RMW (Configured Address Read Multiple Write, reading of a physical area with fixed addressing, multiple writing)

19.2.3 Addressing and FMMUs

In order to address a slave in the EtherCAT® system, various methods from the master can be used. The sensor supports as full slave:

- Position addressing
The slave device is addressed via its physical position in the EtherCAT® segment. The services used for this are APRD, APWR, APRW
- Node addressing
The slave device is addressed via a configured node address that was assigned by the master during the commissioning phase. The services used for this are FPRD, FPWR and FPRW
- Logical addressing
The slaves are not addressed individually; instead, a section of the segment-wide logical 4 GB address is addressed. This segment can be used by a number of slaves. The services used for this are LRD, LWR and LRW.

The local assignment of physical slave memory addresses and logical segment-wide addresses is implemented via the Field Bus Memory Management Units (FMMUs). The configuration of the slave FMMUs is implemented by the master. The FMMU configuration contains a start address of the physical memory in the slave, a logical start address in the global address space, length and type of the data, as well as the direction (input or output) of the process data.

19.2.4 Sync manager

Sync managers serve the data consistency during the data exchange between EtherCAT® master and slaves. Each Sync Manager channel defines an area of the application memory. The sensor has four channels.

Sync-manager channel 0	Sync manager 0 is used for mailbox write transfers (mailbox from master to slave).
Sync-manager channel 1	Sync manager 1 is used for mailbox read transfers (mailbox from slave to master).
Sync-manager channel 2	Sync manager 2 is normally used for process output data. Not used in the sensor.
Sync-manager channel 3	Sync manager 3 is used for process input data. It contains the Tx PDOs that are specified by the PDO assignment object 0x1C13 (hex.).

19.2.5 EtherCAT® state machine

The EtherCAT® state machine is implemented in each EtherCAT® slave. Immediately after switching on the sensor, the state machine is in the "Initialization" state. In this state, the master has access to the DLL information register of the slave hardware. The mailbox is not yet initialized, i.e. communication with the application (sensor software) is not yet possible. During the transition to the pre-operational state, the Sync Manager channels are configured for the mailbox communication. In the "Pre-Operational" state, communication via the mailbox is possible, and it can access the object directory and its objects. In this state, no process data communication occurs. During the transition to the "Safe-Operational" state, the process-data mapping, the Sync Manager channel of the process inputs and the corresponding FMMU are configured by the master. Mailbox communication continues to be possible in the "Safe-Operational" state. The process data communication runs for the inputs. The outputs are in the "safe" state. In the "Operational" state, process data communication runs for both the inputs and the outputs

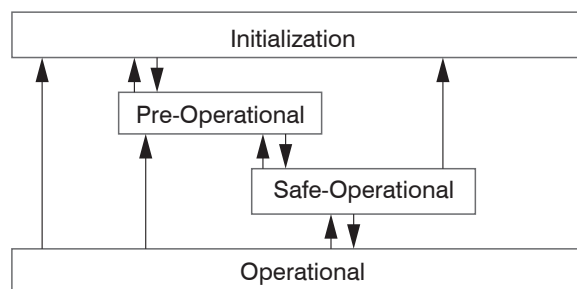

Fig. 19.2: EtherCAT®State machine

19.2.6 CANopen via EtherCAT®

The application level communication protocol in EtherCAT® is based on the communication profile CANopen DS 301 and is designated either as "CANopen over EtherCAT®" or CoE. The protocol specifies the object directory in the sensor, as

well as the communication objects for the exchange of process data and acyclic messages. The sensor uses the following message types:

- Process Data Object (PDO). The PDO is used for the cyclic I/O communication, therefore for process data.
- Service Data Object (SDO). The SDO is used for acyclic data transmission

The object directory is described in the chapter CoE Object Directory.

19.2.7 Prozessdaten PDO-Mapping

Prozessdatenobjekte (PDOs) werden für den Austausch von zeitkritischen Prozessdaten zwischen Master und Slave verwendet. Tx PDOs werden für die Übertragung von Daten vom Slave zum Master verwendet (Eingänge). Rx PDOs werden verwendet, um Daten vom Master zum Slave (Ausgänge) zu übertragen; dies wird im Sensor nicht verwendet. Die PDO Abbildung (Mapping) definiert, welche Anwendungsobjekte (Messdaten) in einem PDO übertragen werden.

Beim Sensor kann aus einer Reihe von Tx PDO-Mapping-Objekten ausgewählt werden.

In EtherCAT® werden PDOs in Objekten des Sync-Manager-Kanals transportiert. Der Sensor benutzt den Sync-Manager-Kanal SM3 für Eingangsdaten (Tx-Daten). Die PDO-Zuweisungen des Sync Managers können nur im Zustand „Pre-Operational“ geändert werden.

- | | |
|---|--|
| i | Subindex 0h des Objektes 0x1A00 enthält die Anzahl gültiger Einträge innerhalb des Abbildungsberichts. Diese Zahl steht auch für die Anzahl der Anwendungsvariablen (Parameter), die mit dem entsprechenden PDO übertragen/empfangen werden sollen. Die Subindizes von 1h bis zur Anzahl von Objekten enthalten Informationen über die abgebildeten Anwendungsvariablen. Die Abbildungswerte in den CANopen-Objekten sind hexadezimal codiert. |
|---|--|

Die folgende Tabelle enthält ein Beispiel der Eintragsstruktur der PDO-Abbildung:

MSB ... LSB		
31 ... 16	15 ... 8	7 ... 0
Index z. B. 0x6000 (16 Bit)	Subindex z.B. 0x01	Objektlänge in Bit, z. B. 20h = 32 Bits

Tab. 19.1: Eintragsstruktur der PDO-Abbildung, Beispiel

19.2.8 Service data SDO service

Service Data Objects (SDOs) are primarily used for the transmission of data that is not time critical, e.g. parameter values.

EtherCAT® specifies

- SDO services: these make possible the read/write access to entries in the CoE object directory of the device.
- SDO information services make it possible to read the object directory itself and to access the properties of the objects.

All parameters of the measuring device can be read or changed in this way, or measurements can be transmitted. A desired parameter is addressed via index and sub-index within the object directory.

19.3 CoE object directory

The CoE object directory (CANopen over EtherCAT®) contains all the configuration data of the sensor. The objects in CoE object directory can be accessed using the SDO services. Each object is addressed using a 16-bit index. With each build, the file object_documentation.csv is generated for the sensor, listing all objects.

19.3.1 Communication-specific standard objects

19.3.1.1 Overview

Index (h)	Name	Description
1000	Device type	Device type
1008	Device name	Manufacturer device name
1009	Hardware version	Hardware version

100 A	Software version	Software version
1015	Identity	Device identification
10F8	Timestamp	EtherCAT stack predefined object, not to be confused with the timestamp of the process data
1A00 ... 01A16		TxPDO mapping, see Chap. 19.4.1 In some cases, several process data (mappable objects - process data) are combined in the PDO mapping objects.
1C00	Sync. manager type	Synchronous manager type
1C12	RxPDO assign	
1C13	TxPDO assign	TxPDO assign
1C32	Sync manager output parameter	Synchronous mode parameter (DC)
1C33	Sync manager input parameter	

Tab. 19.2: Overview standard objects

19.3.1.2 Object 1001h: Device type

1001	VAR	Device type	0x00000000	Unsigned32	ro
------	-----	-------------	------------	------------	----

Provides information about the device profile and the device type used.

19.3.1.3 Object 1008h: Manufacturer device name

1008	VAR	Device name	ILD5500	Visible string	ro
------	-----	-------------	---------	----------------	----

19.3.1.4 Object 1009h: Hardware version

1009	VAR	Hardware version	21	Visible String	ro
------	-----	------------------	----	----------------	----

19.3.1.5 Object 100Ah: Software version

100 A	VAR	Software version	014,000	Visible String	ro
-------	-----	------------------	---------	----------------	----

19.3.1.6 Object 100B: Bootloader

100B	VAR	Bootloader version		Visible String	ro
------	-----	--------------------	--	----------------	----

19.3.1.7 Object 1018h: Device identification

1008	RECORD	Device name	Identity		
------	--------	-------------	----------	--	--

Sub-indices

0	VAR	Number of entries	4	Unsigned8	ro
1	VAR	Vendor ID	0x00000607	Unsigned32	ro
2	VAR	Product code	0x60CB01F6	Unsigned32	ro
3	VAR	Revision	0x00010000	Unsigned32	ro
4	VAR	Serial number	0x13223A25	Unsigned32	ro

The product code identifies an EtherCAT device in the network. This identification is made up of vendor ID, product code and revision. Serial number contains the serial number of the sensor

19.3.1.8 TxPDO mapping

Object ID	Description	Sub-index	Access	Data type
0x1A00	Shutter TxPDOMap OV1	001	ro	UINT32
0x1A01	Shutter TxPDOMap OV2	001, 002	ro	UINT32
0x1A02	Shutter TxPDOMap OV4	001,...,004	ro	UINT32
0x1A03	Shutter TxPDOMap OV8	001,...,008	ro	UINT32
0x1A10	Frequency TxPDOMap OV1	001	ro	UINT32
0x1A11	Frequency TxPDOMap OV2	001.002	ro	UINT32
0x1A12	Frequency TxPDOMap OV4	001,...,004	ro	UINT32
0x1A13	Frequency TxPDOMap OV8	001,...,008	ro	UINT32
0x1A20	Frame time stamp TxPDOMap OV1	001	ro	UINT32
0x1A21	Frame time stamp TxPDOMap OV2	001.002	ro	UINT32
0x1A22	Frame time stamp TxPDOMap OV4	001,...,004	ro	UINT32
0x1A23	Frame time stamp TxPDOMap OV8	001,...,008	ro	UINT32
0x1A30	Frame counter TxPDOMap OV1	001	ro	UINT32
0x1A31	Frame counter TxPDOMap OV2	001.002	ro	UINT32
0x1A32	Frame counter TxPDOMap OV4	001,...,004	ro	UINT32
0x1A33	Frame counter TxPDOMap OV8	001,...,008	ro	UINT32
0x1A40	Frame status TxPDOMap OV1	001	ro	UINT32
0x1A41	Frame status TxPDOMap OV2	001.002	ro	UINT32
0x1A42	Frame status TxPDOMap OV4	001,...,004	ro	UINT32
0x1A43	Frame status TxPDOMap OV8	001,...,008	ro	UINT32
0x1A50	Unlin TxPDOMap OV1	001	ro	UINT32
0x1A51	Unlin TxPDOMap OV2	001.002	ro	UINT32
0x1A52	Unlin TxPDOMap OV4	001,...,004	ro	UINT32
0x1A53	Unlin TxPDOMap OV8	001,...,008	ro	UINT32
0x1A60	Intensity TxPDOMap OV1	001	ro	UINT32
0x1A61	Intensity TxPDOMap OV2	001.002	ro	UINT32
0x1A62	Intensity TxPDOMap OV4	001,...,004	ro	UINT32
0x1A63	Intensity TxPDOMap OV8	001,...,008	ro	UINT32
0x1A70	Lin TxPDOMap OV1	001	ro	UINT32
0x1A71	Lin TxPDOMap OV2	001.002	ro	UINT32
0x1A72	Lin TxPDOMap OV4	001,...,004	ro	UINT32
0x1A73	Lin TxPDOMap OV8	001,...,008	ro	UINT32
0x1A80	Peak 1 distance TxPDOMap OV1	001	ro	UINT32
0x1A81	Peak 1 distance TxPDOMap OV2	001.002	ro	UINT32
0x1A82	Peak 1 distance TxPDOMap OV4	001,...,004	ro	UINT32
0x1A83	Peak 1 distance TxPDOMap OV8	001,...,008	ro	UINT32

0x1A90	User calc 01 TxPDOMap OV1	001	ro	UINT32
0x1A91	User calc 01 TxPDOMap OV2	001.002	ro	UINT32
0x1A92	User calc 01 TxPDOMap OV4	001,...,004	ro	UINT32
0x1A93	User calc 01 TxPDOMap OV8	001,...,008	ro	UINT32
0x1AA0	User calc 02 TxPDOMap OV1	001	ro	UINT32
0x1AA1	User calc 02 TxPDOMap OV2	001.002	ro	UINT32
0x1AA2	User calc 02 TxPDOMap OV4	001,...,004	ro	UINT32
0x1AA3	User calc 02 TxPDOMap OV8	001,...,008	ro	UINT32
0x1AB0	User calc 03 TxPDOMap OV1	001	ro	UINT32
0x1AB1	User calc 03 TxPDOMap OV2	001.002	ro	UINT32
0x1AB2	User calc 03 TxPDOMap OV4	001,...,004	ro	UINT32
0x1AB3	User calc 03 TxPDOMap OV8	001,...,008	ro	UINT32
0x1AC0	User calc 04 TxPDOMap OV1	001	ro	UINT32
0x1AC1	User calc 04 TxPDOMap OV2	001.002	ro	UINT32
0x1AC2	User calc 04 TxPDOMap OV4	001,...,004	ro	UINT32
0x1AC3	User calc 04 TxPDOMap OV8	001,...,008	ro	UINT32
0x1AD0	User calc 05 TxPDOMap OV1	001	ro	UINT32
0x1AD1	User calc 05 TxPDOMap OV2	001.002	ro	UINT32
0x1AD2	User calc 05 TxPDOMap OV4	001,...,004	ro	UINT32
0x1AD3	User calc 05 TxPDOMap OV8	001,...,008	ro	UINT32
0x1AE0	User calc 06 TxPDOMap OV1	001	ro	UINT32
0x1AE1	User calc 06 TxPDOMap OV2	001.002	ro	UINT32
0x1AE2	User calc 06 TxPDOMap OV4	001,...,004	ro	UINT32
0x1AE3	User calc 06 TxPDOMap OV8	001,...,008	ro	UINT32
0x1AF0	User calc 07 to 08 TxPDOMap OV1	001.002	ro	UINT32
0x1AF1	User calc 07 to 08 TxPDOMap OV2	001,...,004	ro	UINT32
0x1AF2	User calc 07 to 08 TxPDOMap OV4	001,...,008	ro	UINT32
0x1AF3	User calc 07 to 08 TxPDOMap OV8	001,...,016	ro	UINT32
0x1B00	User calc 09 to 10 TxPDOMap OV1	001.002	ro	UINT32
0x1B01	User calc 09 to 10 TxPDOMap OV2	001,...,004	ro	UINT32
0x1B02	User calc 09 to 10 TxPDOMap OV4	001,...,008	ro	UINT32
0x1B03	User calc 09 to 10 TxPDOMap OV8	001,...,016	ro	UINT32
0x1B10	User calc 11 to 12 TxPDOMap OV1	001.002	ro	UINT32
0x1B11	User calc 11 to 12 TxPDOMap OV2	001,...,004	ro	UINT32
0x1B12	User calc 11 to 12 TxPDOMap OV4	001,...,008	ro	UINT32
0x1B13	User calc 11 to 12 TxPDOMap OV8	001,...,016	ro	UINT32
0x1B20	User calc 13 to 14 TxPDOMap OV1	001.002	ro	UINT32
0x1B21	User calc 13 to 14 TxPDOMap OV2	001,...,004	ro	UINT32
0x1B22	User calc 13 to 14 TxPDOMap OV4	001,...,008	ro	UINT32
0x1B23	User calc 13 to 14 TxPDOMap OV8	001,...,016	ro	UINT32

0x1B30	User calc 15 to 16 TxPDOMap OV1	001.002	ro	UINT32
0x1B31	User calc 15 to 16 TxPDOMap OV2	001,...,004	ro	UINT32
0x1B32	User calc 15 to 16 TxPDOMap OV4	001,...,008	ro	UINT32
0x1B33	User calc 15 to 16 TxPDOMap OV8	001,...,016	ro	UINT32
0x1B40	User calc 17 to 18 TxPDOMap OV1	001.002	ro	UINT32
0x1B41	User calc 17 to 18 TxPDOMap OV2	001,...,004	ro	UINT32
0x1B42	User calc 17 to 18 TxPDOMap OV4	001,...,008	ro	UINT32
0x1B43	User calc 17 to 18 TxPDOMap OV8	001,...,016	ro	UINT32
0x1B50	User calc 19 to 20 TxPDOMap OV1	001.002	ro	UINT32
0x1B51	User calc 19 to 20 TxPDOMap OV2	001,...,004	ro	UINT32
0x1B52	User calc 19 to 20 TxPDOMap OV4	001,...,008	ro	UINT32
0x1B53	User calc 19 to 20 TxPDOMap OV8	001,...,016	ro	UINT32
0x1B60	User calc 21 to 24 TxPDOMap OV1	001,...,004	ro	UINT32
0x1B61	User calc 21 to 24 TxPDOMap OV2	001,...,008	ro	UINT32
0x1B62	User calc 21 to 24 TxPDOMap OV4	001,...,016	ro	UINT32
0x1B63	User calc 21 to 24 TxPDOMap OV8	001,...,032	ro	UINT32
0x1B70	User calc 25 to 28 TxPDOMap OV1	001,...,004	ro	UINT32
0x1B71	User calc 25 to 28 TxPDOMap OV2	001,...,008	ro	UINT32
0x1B72	User calc 25 to 28 TxPDOMap OV4	001,...,016	ro	UINT32
0x1B73	User calc 25 to 28 TxPDOMap OV8	001,...,032	ro	UINT32
0x1B80	User calc 29 to 32 TxPDOMap OV1	001,...,004	ro	UINT32
0x1B81	User calc 29 to 32 TxPDOMap OV2	001,...,008	ro	UINT32
0x1B82	User calc 29 to 32 TxPDOMap OV4	001,...,016	ro	UINT32
0x1B83	User calc 29 to 32 TxPDOMap OV8	001,...,032	ro	UINT32
0x1B90	User calc 33 to 36 TxPDOMap OV1	001,...,004	ro	UINT32
0x1B91	User calc 33 to 36 TxPDOMap OV2	001,...,008	ro	UINT32
0x1B92	User calc 33 to 36 TxPDOMap OV4	001,...,016	ro	UINT32
0x1B93	User calc 33 to 36 TxPDOMap OV8	001,...,032	ro	UINT32
0x1BA0	User calc 37 to 40 TxPDOMap OV1	001,...,004	ro	UINT32
0x1BA1	User calc 37 to 40 TxPDOMap OV2	001,...,008	ro	UINT32
0x1BA2	User calc 37 to 40 TxPDOMap OV4	001,...,016	ro	UINT32
0x1BA3	User calc 37 to 40 TxPDOMap OV8	001,...,032	ro	UINT32

You can only select PDO mappings with the same oversampling. If the sensor is integrated using an ESI file, the PDO mappings may already be configured as mutually exclusive, depending on the PLC software. If this is not the case because the PLC engineering software does not support this function or because the sensor was connected online without an ESI file, an invalid PDO mapping combination results in an error message and the process data is not transferred to the EtherCAT master.

19.3.1.9 Object 1C00h: Synchronous manager type

1C00	RECORD	Sync manager type			ro
------	--------	-------------------	--	--	----

Sub-indices

0	VAR	Number of entries	4	Unsigned8	ro
1	VAR	Sync manager 1	0x01	Unsigned8	ro
2	VAR	Sync manager 2	0x02	Unsigned8	ro
3	VAR	Sync manager 3	0x03	Unsigned8	ro
4	VAR	Sync manager 4	0x04	Unsigned8	ro

For details, see the section on data exchange between EtherCAT® master and slave, see [Chap. 19.2.4](#).

19.3.1.10 Object 1C12h: RxPDO assign

1C12	ARRAY	RxPDO assign			rw
------	-------	--------------	--	--	----

Sub-indices

0	VAR	Number of entries	0	Unsigned8	ro
---	-----	-------------------	---	-----------	----

No RxPDOs can be selected because none are present. The object is implemented as a dummy to enable the EtherCAT master to set the RxPDOs to 0.

19.3.1.11 Object 1C13h: TxPDO assign

1C13	ARRAY	TxPDO assign			rw
------	-------	--------------	--	--	----

Sub-indices

0	VAR	Number of entries	n	Unsigned8	rw
1	VAR	Sub-index 001	0x1A00	Unsigned16	rw
2	VAR	Sub-index 002	0x1A04	Unsigned16	rw
..					
6	VAR	Sub-index 006	0x1A14	Unsigned16	rw

Object for selecting the PDOs (TxPDO maps).

19.3.1.12 Object 1C32h: Sync manager output parameters

See description of input parameters, see [Chap. 19.3.1.13](#).

19.3.1.13 Object 1C33h: Sync manager input parameters

1C33	RECORD	SM input parameter			ro
------	--------	--------------------	--	--	----

Sub-indices

0	VAR	Number of entries	9	Unsigned8	ro
1	VAR	Synchronization type	x	Unsigned16	ro
2	VAR	Cycle time	x	Unsigned32	ro
4	VAR	Synchronization types supported	0x4007	Unsigned16	ro
5	VAR	Minimum cycle time	100000	Unsigned32	ro
6	VAR	Calc and copy time	x	Unsigned32	ro
8	VAR	Get cycle time	x	Unsigned16	ro
9	VAR	Delay time	x	Unsigned32	ro
0C	VAR	Cycle time too small counter	x	Unsigned16	ro
20	VAR	Sync error	x	bit	ro

- Synchronization type: Currently specified synchronization.
- Cycle time: Currently specified cycle time in μs
 - Free run: The cycle time derived from the measuring rate.

- Sync0 synchronization, the Sync0 cycle time set by the master.
- Minimum cycle time: The minimum cycle time is derived from the maximum measuring rate and is 100 µs.
- Calc and Copy Time: The Calc and Copy time is the time after the input latch (input data are available in the slave) until the input data is copied into the Sync-Manager-3 area (transfer of the data to Industrial Ethernet). The Calc and Copy Time from 0x1C33 is only calculated if the Distributed Clocks are enabled. The value is recalculated each time it is read. Since the sensor does not have output data, the Calc and copy time of 0x1C32 always returns to 0.
The Calc and Copy Time update is triggered once (via sub-index 8) when the sub-index is set to true. If the sub-index is set to false, 0 is returned as Calc and Copy Time.
- Delay time: The delay time is the hardware-related delay until the input latch is reached.
- The delay time from 0x1C33 is only calculated if the Distributed Clocks are activated. The value is recalculated each time it is read. Since the sensor does not have output data, the Delay time from 0x1C32 always returns to 0.
- Cycle Time Too Small Counter: This counter is incremented if the cycle time is too low, so that the input data could not be provided for the next SM event.
- Sync error
 - 0: No errors.
 - 1: A synchronization occurred. The Cycle Time Too Small Counter has been incremented.

The set synchronization depends on the combination of 0x1C33:001 and 0x1C32:001. The synchronization changes during a transition from the PreOP state to the SafeOP state. If the combination is invalid, an error message is displayed when the state is changed. Process data communication will then not be possible.

0x1C32 Synchronization Type	0x1C33 Synchronization Type	Synchronization
0x00	0x00	Free run
0x01	0x22	SM2
0xyy	0x01	SM3
0x02	0x02	Sync0

Tab. 19.3: Example of synchronization

An activation of the Distributed Clocks does not automatically change the Sync0 mode. The synchronization can only be changed by writing the objects 0x1C32 and 0x1C33.

19.3.2 Manufacturer-specific objects

Overview

Index (h)	Name	Description
3002	Sensor error	Sensor error
3005	Controller info	Controller information
3020	Synchronization	Synchronization
3100	Measuring	Measurement
3101	Measuring task	Measuring task
3102	Counter reset	Reset counter
3103	Range of interest	Relevant range
3104	Exposure	Exposure
3105	Peak selection	Selection of peak values
3107	Field linearization	
3200	Comp available signals	Available signals
3210...	Comp 1...	
3219	Comp 10	
3300	Mastering available signals	Signal detection
3310...	Mastering 1...	
3319	Mastering 10	
3320	Statistic available signals	Analysis/Display

3330...	Statistic 1...	
3339	Statistic 10	
3350	User calc	User-specific calculation/data processing
3501	Basic settings	Basic setting
3503	Meassettings	Setting/Configuration
3510	User level	Permission
3520	Reset	Resetting
3521	Factory reset	Factory settings
3530	Laser power	Laser light source
6000	Out_shutter	Output value exposure time
6001	Out_frequency	Output value measuring rate
6002	Out_frametimestamp	Output value time stamp
6003	Out_framecounter	Output value of measurement counter
6004	Out_framestatus	Output value frame status
6005	Out_01_md_unlin	Output value of non-linearized distance value
6006	Out_md_intensity	Output value intensity
6007	Out_01_md_lin	Output value of linearized distance value
6008	Out_01_peak1_distance	Output value peak distance
7000...	UserCalc01	User-specific calculation/data processing
7027	UserCalc40	User-specific calculation/data processing

The following is a description of the individual objects with their sub-indices. A description of the functionality of the sensor parameters can be found in the relevant sections of the sensor operating instructions.

19.3.2.1 Object 3000h: Light source

3000	RECORD	Laser power			
------	--------	-------------	--	--	--

Sub-indices

0	VAR	Number of entries	1	UINT8	ro
1	VAR	Laser power	x	UINT8	rw

For more information, please refer to the Inputs section.

Laser power:

0 - Off,

1 - Full,

2 - Reduced

19.3.2.2 Object 3002: Sensor error

3021	RECORD	Sensor error			ro
------	--------	--------------	--	--	----

Sub-indices

0	VAR	Number of entries	2	Uint8	ro
1	VAR	Error number	x	Uint8	ro
2	VAR	Error description		Visible string	ro

- Sensor error number: Output of the sensor error during communication
- Sensor error description: Sensor error as plain text

19.3.2.3 Object 3005: Controller info

3005	RECORD	Controller info			
------	--------	-----------------	--	--	--

Sub-indices

0	VAR	Number of entries	12	Uint8	ro
6	VAR	Option		String	ro
8	VAR	Article number		String	ro
9	VAR	Measuring range		Float	ro
10	VAR	Variant		String	ro
11	VAR	Software revision		String	ro
12	VAR	FPGA version		String	ro

19.3.2.4 Object 3020: Synchronization

3020	RECORD	Synchronization			
------	--------	-----------------	--	--	--

Sub-indices

0	VAR	Number of entries	8	Uint8	ro
3	VAR	Alternating slave mode		BIT	rw

19.3.2.5 Object 3100: Measuring

3100	RECORD	Measuring			
------	--------	-----------	--	--	--

Sub-indices

0	VAR	Number of entries	1	Uint8	ro
1	VAR	Measuring rate [kHz]		Float	rw

19.3.2.6 Object 3101: Measurement task

3101	RECORD	Measurement task			
------	--------	------------------	--	--	--

Sub-indices

0	VAR	Number of entries	1	Uint8	rw
---	-----	-------------------	---	-------	----

19.3.2.7 Object 3102: Counter reset

3102	RECORD	Counter reset			
------	--------	---------------	--	--	--

Sub-indices

0	VAR	Number of entries	8	Uint8	ro
1	VAR	Reset counter		BIT	wo
2	VAR	Reset timestamp		BIT	wo

If sub-index 1 is set to 1, the time stamp (0x7001) is reset.

Setting sub-index 2 to 1 resets the measured value counter (0x7000).

19.3.2.8 Object 3103: Range of interest

3101	RECORD	Range of interest			
------	--------	-------------------	--	--	--

Sub-indices

0	VAR	Number of entries	2	Uint8	ro
1	VAR	Start of range		Uint16	rw
2	VAR	End of range		Uint16	rw

19.3.2.9 Object 3104: Exposure

3104	RECORD	Exposure			
------	--------	----------	--	--	--

Sub-indices

0	VAR	Number of entries	5	Uint8	ro
1	VAR	Shutter mode		Uint8	rw
2	VAR	Shutter value [us]		Float	rw
3	VAR	Exposure mode		Uint8	rw
4	VAR	Exposure limit max		Float	rw
5	VAR	Exposure limit min		Float	rw

19.3.2.10 Object 3105: Peak selection

3105	RECORD	Peak selection			
------	--------	----------------	--	--	--

Sub-indices

0	VAR	Number of entries	2	Uint8	rw
---	-----	-------------------	---	-------	----

19.3.2.11 Object 3107: Field linearization

3107	RECORD	Field linearization			
------	--------	---------------------	--	--	--

Sub-indices

0	VAR	Number of entries	14	Uint8	ro
1	VAR	Enable/State		BIT	rw
2	VAR	Mode		Uint8	rw
3	VAR	Target distance 1		Float	rw
4	VAR	Target distance 2		Float	rw
5	VAR	Target distance 3		Float	rw
6	VAR	Measure distance 1		BIT	wo
7	VAR	Measure distance 2		BIT	wo
8	VAR	Measure distance 3		BIT	wo
9	VAR	Get measured distance 1		Float	ro
10	VAR	Get measured distance 2		Float	ro
11	VAR	Get measured distance 3		Float	ro
12	VAR	Coefficient a0		Float	ro
13	VAR	Coefficient a1		Float	ro
14	VAR	Coefficient a2		Float	ro

19.3.2.12 Object 3200: Comp available signals

3200	RECORD	Range of interest			
------	--------	-------------------	--	--	--

Sub-indices

0	VAR	Number of entries		UInt8	ro
---	-----	-------------------	--	-------	----

19.3.2.13 Object 3210...3219: ComP

3210	RECORD	Comp 1			
...		...			
3219		Comp 10			

Sub-indices

0	VAR	Number of entries	8	UInt8	ro
1	VAR	Type		UInt8	rw
3	VAR	Signal1		Visible string	rw
8	VAR	Parameter		UInt8	rw

19.3.2.14 Object 3300: Mastering available signals

3200	RECORD	Mastering available signals			
------	--------	-----------------------------	--	--	--

Sub-indices

0	VAR	Number of entries		Visible string	ro
---	-----	-------------------	--	----------------	----

19.3.2.15 Object 3310...3319: Mastering

3310	RECORD	Mastering 1			
...		...			
3319		Mastering 10			

Sub-indices

0	VAR	Number of entries	4	UInt8	ro
1	VAR	Enabled		BIT	rw
2	VAR	Signal1		Visible string	rw
3	VAR	Value		Float	rw
4	VAR	Set/Reset		BIT	rw

19.3.2.16 Object 3320: Statistic available signals

3320	RECORD	Statistic available signals			
------	--------	-----------------------------	--	--	--

Sub-indices

0	VAR	Number of entries		Visible string	ro
---	-----	-------------------	--	----------------	----

19.3.2.17 Object 3330...3339: Statistic

3330	RECORD	Statistic 1			
...		...			
3339		Statistic 10			

Sub-indices

0	VAR	Number of entries	5	Uint8	ro
1	VAR	Enabled		BIT	rw
2	VAR	Signal		Visible string	rw
3	VAR	Infinite		BIT	rw
4	VAR	Depth		Uint16	rw
5	VAR	Reset		BIT	

19.3.2.18 Object 3350: Signals on user calcs

3350	RECORD	Signals on user calcs			
------	--------	-----------------------	--	--	--

Sub-indices

0	VAR	Number of entries	40	Uint8	ro
1	VAR	User calc 1		Visible string	ro
...
40	VAR	User calc 40		Float	ro

19.3.2.19 Object 3501: Basic settings

3501	RECORD	Basicsettings			
------	--------	---------------	--	--	--

Sub-indices

0	VAR	Number of entries	3	UNIT8	ro
1	VAR	Basicsettings read		BIT	wo
2	VAR	Basicsettings store		BIT	wo
3	VAR	Basicsettings reset		BIT	wo

- `Basicsettings` READ: Loading the last basic settings saved
- `Basicsettings` STORE: Saving the current settings
- `Basicsettings` RESET: Resetting the basic settings to factory settings

19.3.2.20 Object 3350: Signals on user calcs

3350	RECORD	Signals on user calcs			
------	--------	-----------------------	--	--	--

Sub-indices

0	VAR	Number of entries	40	Uint8	ro
1	VAR	User calc 1		Visible string	ro
...
40	VAR	User calc 40		Float	ro

19.3.2.21 Object 3510: User level

3510	RECORD	User level			
------	--------	------------	--	--	--

Sub-indices

0	VAR	Number of entries	7	Uint8	ro
1	VAR	Current access authorization		Uint8	ro
2	VAR	Login		Visible string	wo
3	VAR	Logout		BIT	wo
4	VAR	User level when restarting		Uint8	rw
5	VAR	Change password old		Visible string	wo
6	VAR	Change password new		Visible string	wo
7	VAR	Change password repeat		Visible string	wo

For more information, please refer to the Login section.

Actual user, standard user:

0 - User

1 - Professional

Modifying the user level will also change the access rights for objects. At the User level, after logging out, all RW objects are read-only (= ro), and all write-only objects (= wo) are no longer available.

To change the password, you need to complete the three passwords fields (Old, New and Repeat) in this particular order. The maximum password length is 31 characters.

19.3.2.22 Object 3520: Reset

3520	RECORD	Reboot sensor			
------	--------	---------------	--	--	--

Sub-indices

0	VAR	Number of entries		BIT	wo
---	-----	-------------------	--	-----	----

19.3.2.23 Object 3521: Factory reset

3521	RECORD	Factory reset			
------	--------	---------------	--	--	--

Sub-indices

0	VAR	Number of entries		BIT	wo
---	-----	-------------------	--	-----	----

19.3.2.24 Object 3530: Laser power

3530	RECORD	Laser power			
------	--------	-------------	--	--	--

Sub-indices

0	VAR	Number of entries		UNIT8	rw
---	-----	-------------------	--	-------	----

19.4 Mappable objects - process data

19.4.1 General

Displays all individually available process data

The objects 0x600x to 0x6008 are structured as follows:

[INDEX]		[NAME]		
	0	Sub-index 0	UInt8	ro
	1	Sub-index 1	[DATATYPE]	ro

A process data object is an array whose length corresponds to the maximum oversampling. The ILD5500-IE currently supports a maximum oversampling of 4. Object 0x6000 (Frequency) therefore has sub-indices 1, 2, 3, and 4, each of which represents an oversampling value.

The the process data values can also be read asynchronously via SDOs. However, it should be noted that only the value in sub-index 1 can be read. Older values cannot be read acyclically due to oversampling. Sub-indices greater than 1 always return 0.

19.4.1.1 Object 6000: Exposure time

Index	Name	Data type	Access
0x6000	out_shutter	ARRAY	

Sub-indices

0	Number of entries	Unsigned8	ro
1	out_shutter__OV00	Unsigned32	ro
2	out_shutter__OV01	Unsigned32	ro
3	out_shutter__OV02	Unsigned32	ro
4	out_shutter__OV03	Unsigned32	ro
...
8	out_shutter__OV07	Unsigned32	ro

19.4.1.2 Object 6001: Measurement frequency

Index	Name	Data type	Access
0x6001	out_frequency	ARRAY	

Sub-indices

0	Number of entries	Unsigned8	ro
1	out_frequency__OV00	Unsigned32	ro
2	out_frequency__OV01	Unsigned32	ro
3	out_frequency__OV02	Unsigned32	ro
4	out_frequency__OV03	Unsigned32	ro
...
8	out_frequency__OV07	Unsigned32	ro

19.4.1.3 Object 6002: Time stamp

Index	Name	Data type	Access
0x6002	out_frametimestamp	ARRAY	

Sub-indices

0	Number of entries	Unsigned8	ro
1	out_frametimestamp__OV00	Unsigned32	ro
2	out_frametimestamp__OV01	Unsigned32	ro
3	out_frametimestamp__OV02	Unsigned32	ro
4	out_frametimestamp__OV03	Unsigned32	ro
...
8	out_frametimestamp__OV07	Unsigned32	ro

19.4.1.4 Object 6003: Measurement counter

Index	Name	Data type	Access
0x6003	out_framecounter	ARRAY	

Sub-indices

0	Number of entries	Unsigned8	ro
1	out_framecounter__OV00	Unsigned32	ro
2	out_framecounter__OV01	Unsigned32	ro
3	out_framecounter__OV02	Unsigned32	ro
4	out_framecounter__OV03	Unsigned32	ro
...
8	out_framecounter__OV07	Unsigned32	ro

19.4.1.5 Object 6004: Frame status

Index	Name	Data type	Access
0x6004	out_framestatus	ARRAY	

Sub-indices

0	Number of entries	Unsigned8	ro
1	out_framestatus__OV00	Unsigned32	ro
...
8	out_framestatus__OV07	Unsigned32	ro

19.4.1.6 Object 6005: distance value, not linearized

Index	Name	Data type	Access
0x6005	out_01_md_unlin	ARRAY	

Sub-indices

0	Number of entries	Unsigned8	ro
1	out_01_md_unlin__OV00	Unsigned32	ro
...
8	out_01_md_unlin__OV07	Unsigned32	ro

19.4.1.7 Object 6006: Intensity

Index	Name	Data type	Access
0x6006	out_md_intensity	ARRAY	

Sub-indices

0	Number of entries	Unsigned8	ro
1	out_md_intensity__OV00	Unsigned32	ro
...
8	out_md_intensity__OV07	Unsigned32	ro

19.4.1.8 Object 6007: Distance value, linearized

Index	Name	Data type	Access
0x6007	out_01_md_lin	ARRAY	

Sub-indices

0	Number of entries	Unsigned8	ro
1	out_01_md_lin__OV00	Unsigned32	ro
...
8	out_01_md_lin__OV07	Unsigned32	ro

19.4.1.9 Object 6008: Peak distance

Index	Name	Data type	Access
0x6008	out_01_peak1_distance	ARRAY	

Sub-indices

0	Number of entries	Unsigned8	ro
1	out_01_peak1_distance__OV00	Unsigned32	ro
...
8	out_01_peak1_distance__OV07	Unsigned32	ro

19.4.1.10 Object 7000...7009: User calc

Index	Name	Data type	Access
0x70000...0x7009	User calc	ARRAY	

Sub-indices

0	Number of entries	Unsigned8	ro
1	User calc 01__OV00	Unsigned32	ro
2	User calc 01__OV01	Unsigned32	ro
...
8	User calc 01__OV00	Unsigned32	ro

0	Number of entries	Unsigned8	ro
1	User calc 10__OV00	Unsigned32	ro
2	User calc 10__OV01	Unsigned32	ro
...
8	User calc 10__OV07	Unsigned32	ro

19.4.1.11 Object 700A...700F: User calc

Index	Name	Data type	Access
0x700A...0x700F	User calc	ARRAY	

0	Number of entries	Unsigned8	ro
1	User calc 11__OV00	Unsigned32	ro
2	User calc 11__OV01	Unsigned32	ro
...
8	User calc 11__OV07	Unsigned32	ro

...

0	Number of entries	Unsigned8	ro
1	User calc 16__OV00	Unsigned32	ro
2	User calc 16__OV01	Unsigned32	ro
...
8	User calc 16__OV07	Unsigned32	ro

19.4.1.12 Object 7010...7019: User calc

Index	Name	Data type	Access
0x70010...0x7019	User calc	ARRAY	

Sub-indices

0	Number of entries	Unsigned8	ro
1	User calc 17__OV00	Unsigned32	ro
2	User calc 17__OV01		ro
...
8	User calc 17__OV07	Unsigned32	ro

...

0	Number of entries	Unsigned8	ro
1	User calc 26__OV00	Unsigned32	ro
	User calc 26__OV01		ro
...
8	User calc 26__OV07	Unsigned32	ro

19.4.1.13 Object 701A...701F: User calc

Index	Name	Data type	Access
0x7001A...0x701F	User calc	ARRAY	

Sub-indices

0	Number of entries	Unsigned8	ro
1	User calc 27__OV00	Unsigned32	ro
2	User calc 27__OV01	Unsigned32	ro
...
8	User calc 27__OV07	Unsigned32	ro

...

0	Number of entries	Unsigned8	ro
1	User calc 32__OV00	Unsigned32	ro
2	User calc 32__OV01	Unsigned32	ro
...
8	User calc 32__OV07	Unsigned32	ro

19.4.1.14 Object 7020...7027: User calc

Index	Name	Data type	Access
0x70020...0x7029	User calc	ARRAY	

Sub-indices

0	Number of entries	Unsigned8	ro
1	User calc 33__OV00	Unsigned32	ro
2	User calc 33__OV01	Unsigned32	ro
...
8	User calc 33__OV07	Unsigned32	ro

...

0	Number of entries	Unsigned8	ro
1	User calc 40__OV00	Unsigned32	ro
2	User calc 40__OV01	Unsigned32	ro
...
8	User calc 40__OV07	Unsigned32	ro

19.4.2 Error codes for SDO services

If an SDO requirement is evaluated as negative, a corresponding error code is added to the “Abort SDO Transfer Protocol”.

Error code hexadecimal	Meaning
0503 0000	Toggle bit did not change.
0504 0000	SDO protocol timeout expired
0504 0001	Invalid command entered
0504 0005	Insufficient memory
0601 0000	Access to object (parameter) not supported
0601 0001	Attempt to read a “write-only parameter”
0601 0002	Attempt to write a “read-only parameter”
0602 0000	Object (parameter) is not listed in the object directory
0604 0041	Object (parameter) cannot be mapped to PDO
0604 0042	Number or length of objects to be transmitted exceeds PDO length.
0604 0043	General parameter incompatibility
0604 0047	General internal device incompatibility
0606 0000	Access denied due to a hardware error
0607 0010	Incorrect data type or length of the service parameter does not match
0607 0012	Incorrect data type or the service parameter is too long
0607 0013	Incorrect data type or the service parameter is too short
0609 0011	Sub-index does not exist.

Error code hexadecimal	Meaning
0609 0030	Invalid value for the parameter (only for write access)
0609 0031	Value of parameter too high
0609 0032	Value of parameter too low
0609 0036	Maximum value is below minimum value.
0800 0000	General error
0800 0020	Unable to transfer data to the application or unable to save data
0800 0021	Unable to transfer data to the application or unable to save data. Cause: local control
0800 0022	Data cannot be transferred or saved in application due to device status.
0800 0023	Dynamic generation of the object directory failed or no object directory available

19.4.3 Oversampling

In operation without oversampling, the last measured value data set is transferred to the EtherCAT® master with each fieldbus cycle, see Chap. 19.3.1.8.

For long fieldbus cycle times, measurement data sets may therefore not be available. Configurable oversampling ensures that all (or selected) measurement data records are gathered and transmitted together to the master during the next fieldbus cycle. In general, possible oversampling depends on the ratio of the sensor measuring rate to the fieldbus cycle time.

The oversampling factor specifies how many samples are transmitted per bus cycle. Currently the ILD 5500-IE supports oversampling of 1, 2, 4 and 8. An oversampling factor of 2, for example, means that 2 samples are transmitted per bus cycle.

With TxPDO mapping, the base index of the PDO mapping objects is included with oversampling factor 1. Use the following list to determine the index for selecting a different oversampling factor:

- Base index + 1: Oversampling factor 2
- Base index + 2: Oversampling factor 4
- Base index + 3: Oversampling factor 8

You can only select mapping objects with the same oversampling factor in 0x1C13h.

Example:

- The fieldbus/EtherCAT® master operates at a cycle time of 1 ms because the higher-level PLC, for example, works with a cycle time of 1 ms. This means that an EtherCAT® frame is sent to the ILD5500 every 1 ms to retrieve the process data. If the measurement frequency in the sensor is set to 4 kHz, an oversampling factor of 4 must be set.
- Startup procedure to output the distance value with an oversampling factor of 4.
 - The distance value is output in object 0x6007h. In order to transfer this object in the PDO, the PDO mapping object 0x1A10 must be selected in object 0x1C13:01h. However, 0x1A12 (base index 0x1A10 + 2) must be selected for the 4-fold oversampling.

To ensure that no samples are lost due to the asynchronous nature between the master cycle and slave cycle, the master cycle time should always be less than the time for building a block from n samples.

An entire block with the specified samples is only made available to the EtherCAT® side after all specified samples have been written to the block. If the time for filling a block is less than the master cycle time, individual blocks will not be transferred. It can indeed happen that the next block is already being filled with samples before the previously filled block is picked up in a master cycle.

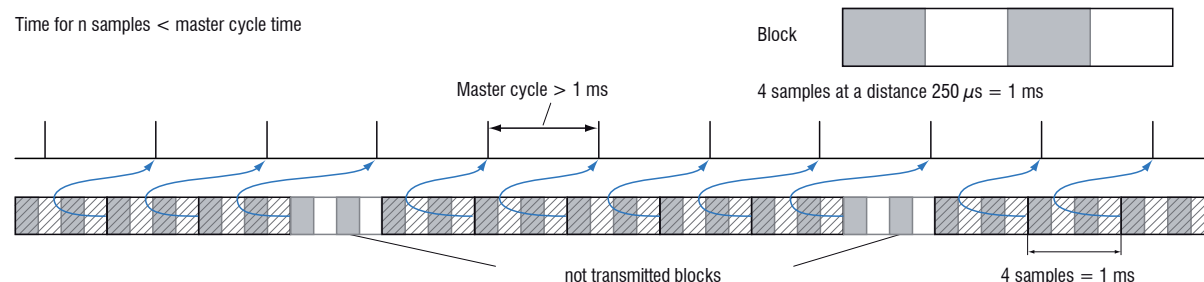

But if you select a number of samples sufficiently large that the time for filling a block is greater than the master cycle time, each block will be picked up in a master cycle. However, individual blocks (and therefore samples) will be transferred two or more times. This can be detected on the master side by transferring the Timestamp or Valuecounter (see object 0x6002, 0x6003).

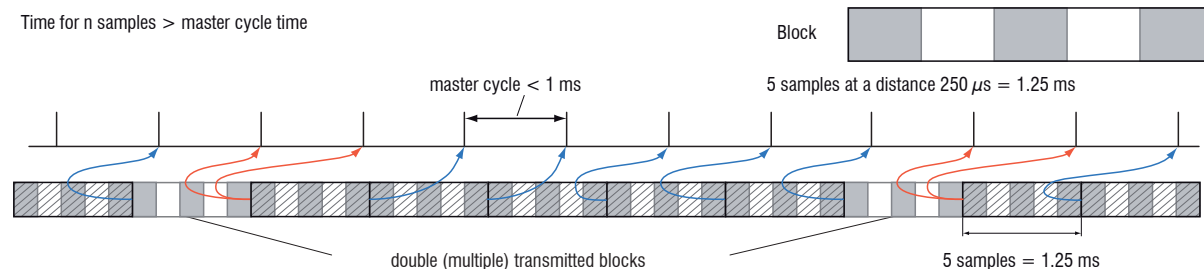

19.4.4 Update

Two options are available to update the firmware of the sensors:

- Update via EoE (Ethernet over EtherCAT®) or Telnet
- Update via FoE (File Access over EtherCAT®)

19.4.4.1 Update via FoE

The sensor can be updated via FoE. For this purpose, a *.mef file is transferred to the sensor via FoE. To do so, the name and password of the file must correspond as follows:

Name: `optoNCDT_5500_000_21.mef`

Password: `0x00000000`

The sensor checks the beginning of the file during transmission. If the file is not in the correct format, the sensor will abort the transfer. After the file has been completely transferred, the sensor automatically starts the update, which disconnects the EtherCAT® master.

19.4.4.2 Update via EoE

An update is performed via a *.meu file. The firmware update tool `Update_Sensor.exe` is required for this.

The current firmware is available at www.micro-epsilon.de/service/download/software.

To execute an update, you have to check `Ethernet` in the firmware update tool and enter the IP address, which you have configured via the EtherCAT® master. With `Refresh` you can check if the sensor can be found on this IP address. Then select the *.meu file via `...` and confirm with `Send update`. First, the update is transmitted to the sensor. After transmission has been completed, the installation will start automatically. Do not disconnect the sensor from the power supply. After the installation is complete, the message `All updates successful` is displayed. Sensor is ready for operation again.

19.4.5 Operational modes

19.4.5.1 Free run

There is no synchronization between the sensor and the EtherCAT® master. The PDOs are updated based on the internal measuring rate. The measuring rate is set using object 0x3200:003. PDO frames may be lost or duplicated. A gapless transmission of the PDO frames to the EtherCAT® master is only given if oversampling and measuring rate are in the right relation to the bus cycle, see [Chap. 19.4.3](#). You can use the measurement counter in 0x6003 so that measured values are not evaluated twice due to the lack of synchronization.

19.4.5.2 Distributed clocks SYNC0 synchronization

Synchronization between the sensor and EtherCAT® master takes place via the Sync0 cycle time. The PDOs are updated based on the Sync0 cycle time, which replaces the internal measuring rate. In this mode, an EtherCAT® master can synchronize the measurement acquisition for the EtherCAT® cycle time and the measurement acquisition of multiple controllers.

Note that although the measurements in the sensor are synchronized to the Sync0 cycle time, the transmission of the values to the EtherCAT® master is again asynchronous with the bus cycle. Synchronous transmission of the values to the EtherCAT® master is only possible if oversampling and Sync0 cycle time are in the correct ratio to the bus cycle, see [Chap. 19.4.3](#).

The ESI file contains predefined SYNC0 cycle times. However, any cycle time from 100000 ns (measuring rate = 10.0 kHz) to 4000000 ns (measuring rate = 0.25 kHz) can be set.

19.4.5.3 SM2/SM3 synchronization

The sensor supplies current data to the EtherCAT master with every SM2 or SM3 event. Please note that the data of the PDOs are updated with the internal measuring rate independent of the bus cycle. This can cause PDO frames to be lost or duplicated. The PDO frames can only be transmitted to the EtherCAT master without gaps if the oversampling and measuring rate are in the correct ratio to the bus cycle, see [Chap. 19.4.3](#).

19.4.6 Meaning of the RUN and ERR LEDs for EtherCAT operation

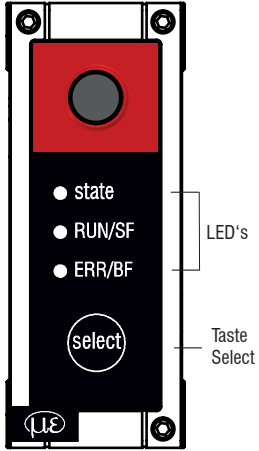
LED RUN	Meaning		
	Green off	INIT state	
	Green flashing 2.5 Hz	PRE-OP condition	
	Green single flash 200 ms ON / 1000 ms OFF	SAFE-OP state	
LED ERR	Meaning		
Red on	No error		
Red flashing 2.5 Hz	Invalid configuration		
Red single flash 200 ms ON / 1000 ms OFF	Status change not requested		
Red double flash 200 ms ON / 200 ms OFF 200 ms ON 400 ms OFF	Watchdog timeout		
Red flashing 10 Hz	Error during initialization		

19.4.7 EtherCAT® Configuration with the Beckhoff TwinCAT® Manager

For example, the Beckhoff TwinCAT Manager can be used as EtherCAT® master on the PC.

The device description files (EtherCAT® Slave Information) `Micro-Epsilon_XXXX.xml` can be found online at www.micro-epsilon.de/download/software/.

- ▶ Copy the device description file into the directory `C:\TwinCAT\3.1\Config\Io\EtherCAT` before the measuring device can be configured using EtherCAT®.
- ▶ Delete any older files that may exist.

EtherCAT® slave information files are XML files which specify the characteristics of the slave device for the EtherCAT® Master and contain information on the communication objects supported.

- ▶ Restart the TwinCAT Manager after copying.

Search for a device:

- ▶ Select the `I/O Devices` tab and then `Scan`.
- ▶ Confirm with `OK`.
- ▶ Select a network card on which to search for EtherCAT® slaves.

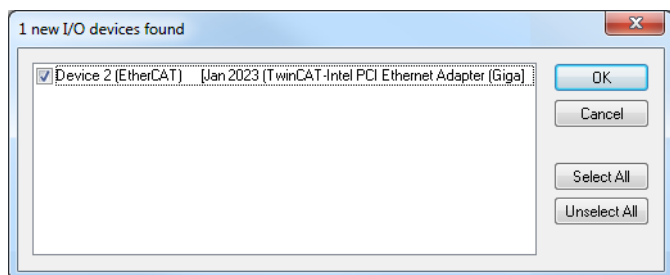

- ▶ Confirm with OK.

The “Scan for boxes” window appears (EtherCAT® slave).

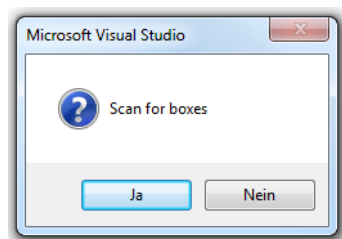

- ▶ Confirm with Yes.

The optoNCDT 5500 is now listed.

- ▶ Now confirm the Activate Free Run window with Yes.

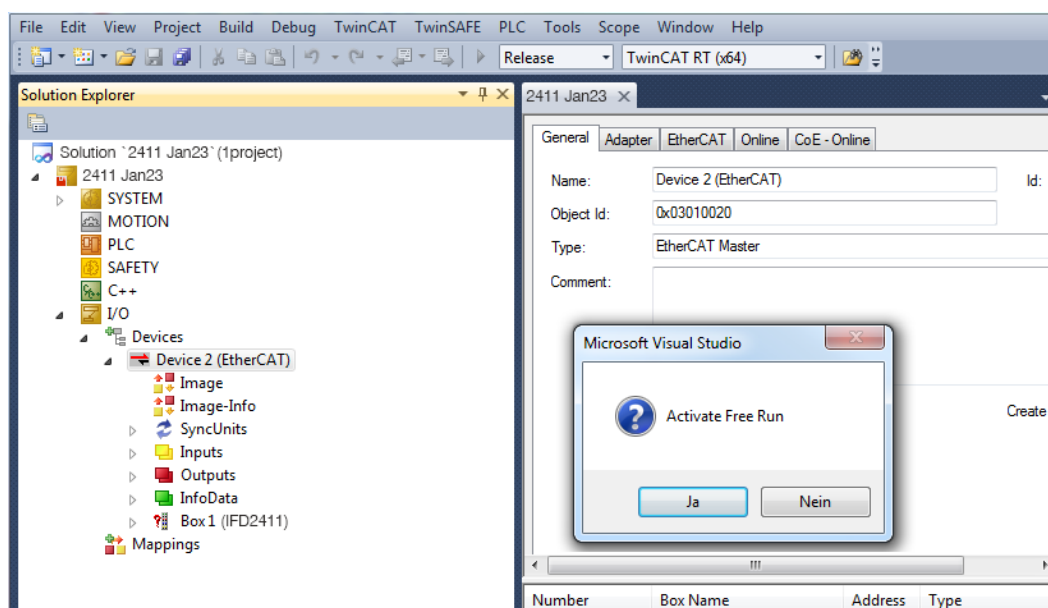

The current status should be at least PREOP, SAFEOP or OP on the Online page.

In the event that ERR PREOP appears in Current State, the cause is reported in the message window. This will be the case when the settings for the PDO mapping in the optoNCDT 5500 are different from the settings in the ESI file (device description file).

In the delivery state of the measuring device, only one measurement value (distance 1) is set as output variable (both in the optoNCDT 5500 and in the ESI file).

Further data can be selected in the Process Data tab.

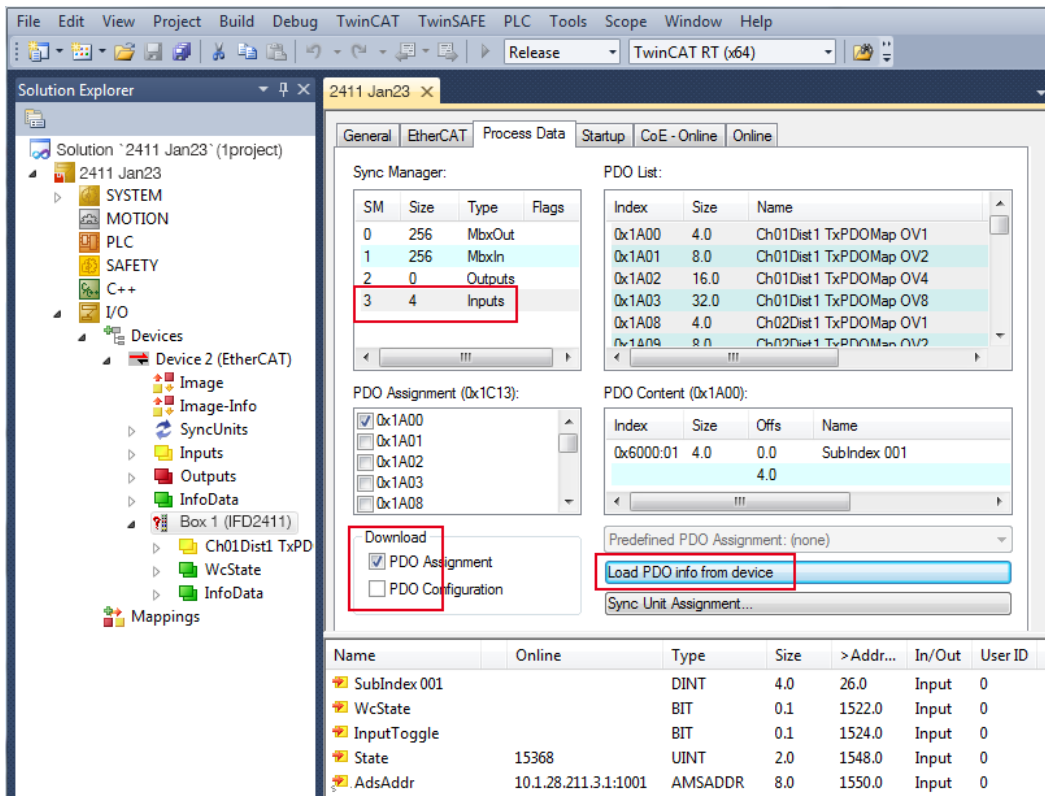

The scope of the process data provided and the assignment of the SyncManager can now be viewed.

- ▶ From the TwinCAT menu select the Restart TwinCAT (Config Mode) tab.

The configuration is now complete.

In SAFEOP and OP status, the selected measurement values are transferred as process data.

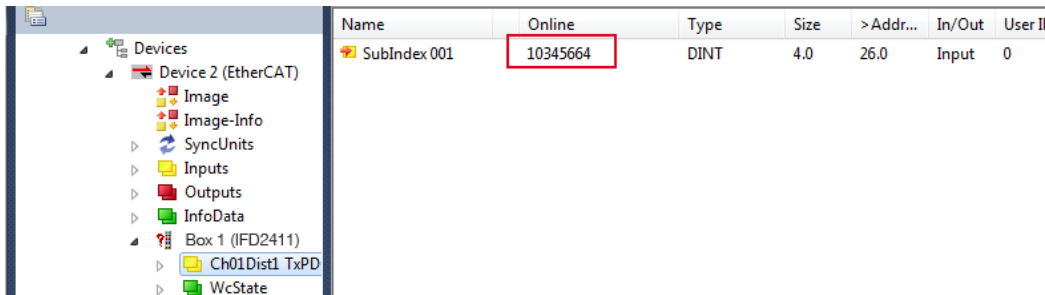



MICRO-EPSILON MESSTECHNIK GmbH & Co. KG
Koenigbacher Str. 15 94496 Ortenburg / Germany
Tel. +49 (0) 8542 / 168-0 Fax +49 (0) 8542 / 168-90
info@micro-epsilon.com <https://www.micro-epsilon.com>
Your local contact: www.micro-epsilon.com/contact/worldwide/

X9751508-A022046EKA
© MICRO-EPSILON MESSTECHNIK