

## Proper Environment

- Protection class: IP65 (applies only when the sensor cable is plugged in)
- Optical inputs are excluded from protection class. Contamination leads to impairment or failure of the function.
- Min. cooling capacity: 940 W
- Max. sensor temperature: 45 °C (113 °F)
- Maximum pressure: 3 bar
- Only fluid cooling media are permissible. Air/gas cooling is not possible.

## Unpacking / Included in Delivery

- 2 cooling plates (only with protective/cooling housing)
- 2 base plates
- 1 protective plate
- 2 protective glasses

## Sensor Mounting, Dimensions

The scanCONTROL sensors are optical sensors for measurements with micrometer accuracy.

**i** Pay attention to careful handling during mounting and operation.

**M** Mount the sensor only to the existing mounting holes/threaded holes on a flat surface. Clamps of any kind are not permitted and can lead to failure of the sensor.

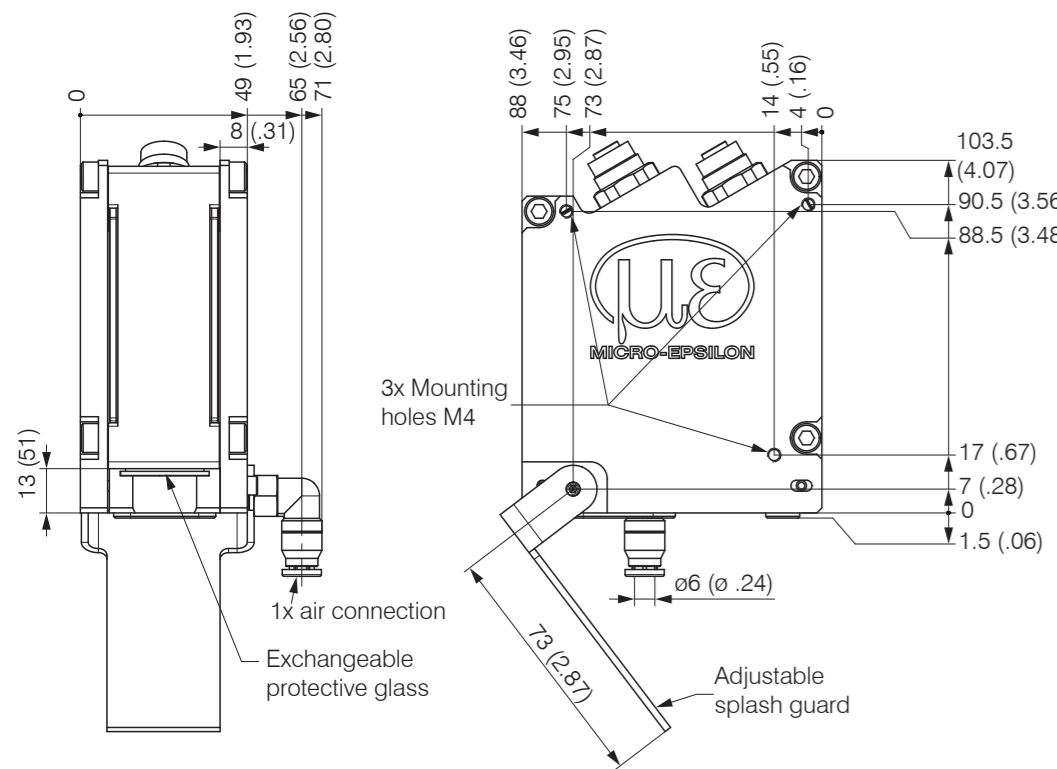

Protective housing with blow-out system, article 2105058, dimensions in mm (inches, rounded off)

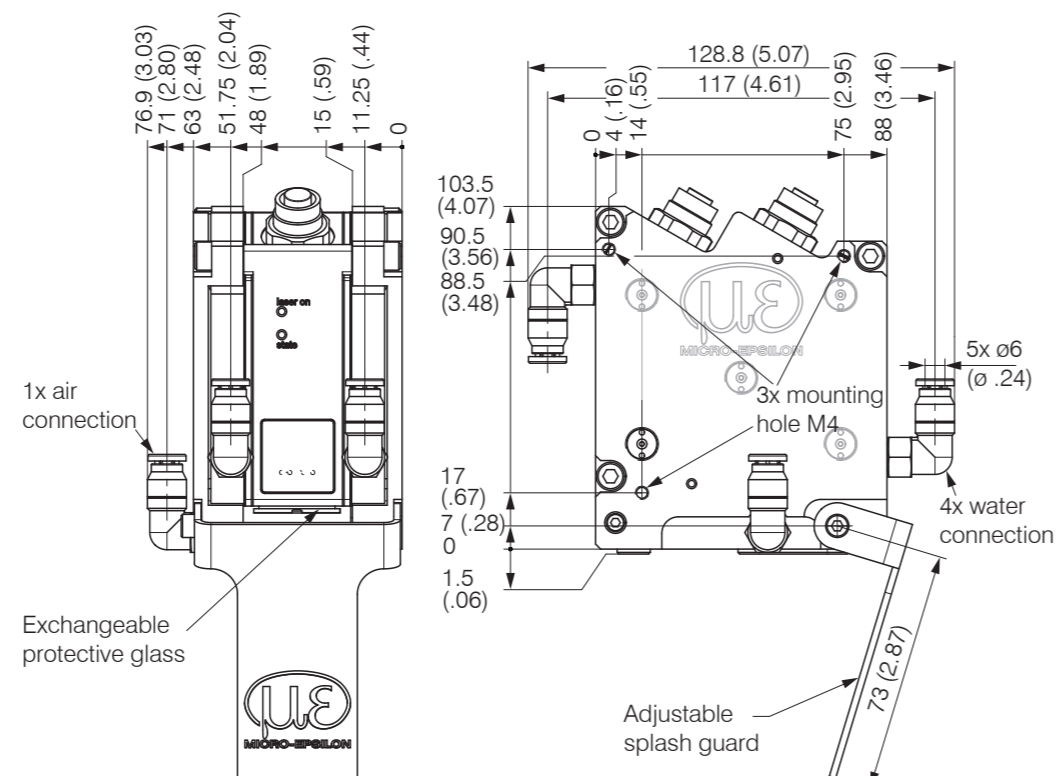

Protective housing with blow-out system and water cooling, article 2105059, dimensions in mm (inches, rounded off)

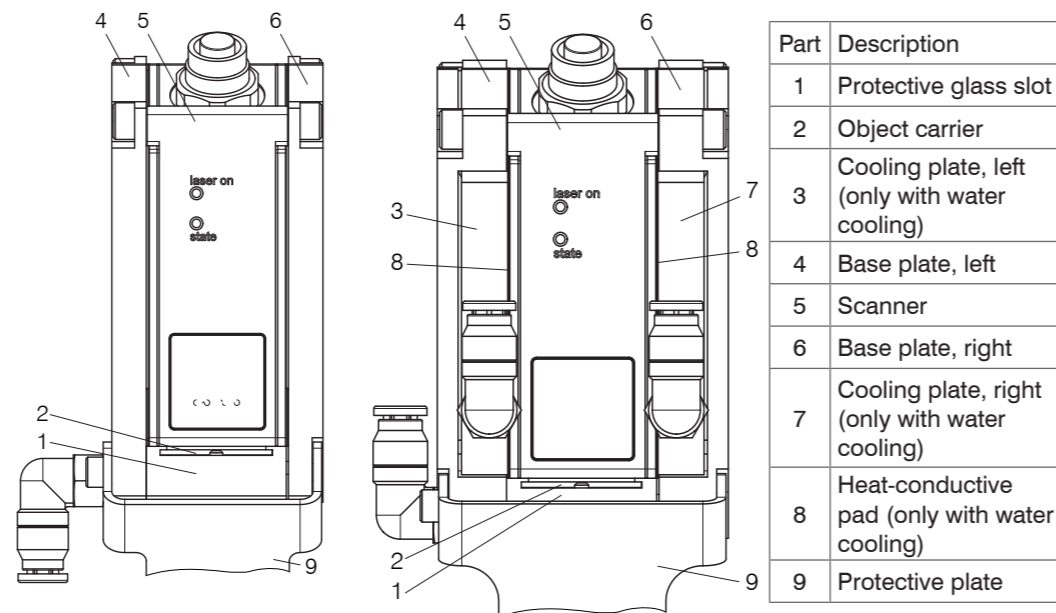

Protective and protective/cooling housing assembly

Part	Description
1	Protective glass slot
2	Object carrier
3	Cooling plate, left (only with water cooling)
4	Base plate, left
5	Scanner
6	Base plate, right
7	Cooling plate, right (only with water cooling)
8	Heat-conductive pad (only with water cooling)
9	Protective plate

## Protective Housing scanCONTROL LLT25xx/26xx/29xx



- Adaptive protective housing for scanCONTROL 25xx/26xx/29xx
- Measuring ranges 25 - 100 mm
  - Air supply of the optical path
  - Exchangeable protective glass

## Protective/Cooling Housing scanCONTROL LLT25xx/26xx/29xx



- Adaptive protective/cooling housing for scanCONTROL 25xx/26xx/29xx
- Measuring ranges 25 - 100 mm
  - Air supply of the optical path
  - Exchangeable protective glass
  - Water cooling circuit for sensor cooling (ambient temperatures up to 95 °C (203 °F))



Assembly Instructions  
**scanCONTROL 25xx/26xx/29xx**  
 Protective housing  
 Protective/Cooling housing

## Use

In dirty environments and with increased ambient temperatures, it is recommended to operate the scanner with a protective or a protective/cooling housing. The protective and protective/cooling housings are optional accessories. Their use may impair the linearity of the sensor in the complete system which is why a referenced measurement is recommended.

The system must only be operated within the limits specified in the technical data. The sensor must be used in such a way that no persons are endangered or machines and other material goods are damaged in the event of malfunction or total failure of the scanner. Take additional precautions for safety and damage prevention in case of safety-related applications.

## Variants

- Protective housing with blow-out system and air supply connection, article 2105058
- Protective/cooling housing with blow-out system, air supply connection and water connections for cooling, article 2105059

## Mounting of Protective/Cooling Housing

If the protective/cooling housing is installed subsequently, make sure that the product labels are removed from the scanner (on the sides).

- Join the right base plate to the protective glass slot. Insert the right cooling plate. Centering pins hold the cooling plate in place.

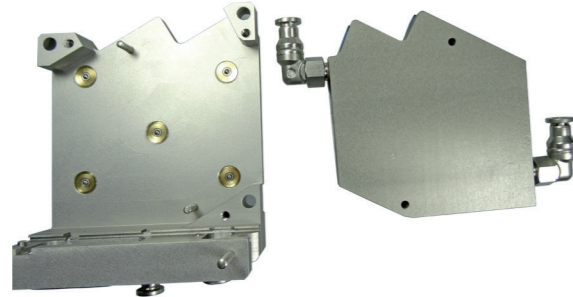

- Remove the protective film from the heat-conducting pad.

- Join the scanner to the right cooling plate.



- Join the left base plate to the left cooling plate.

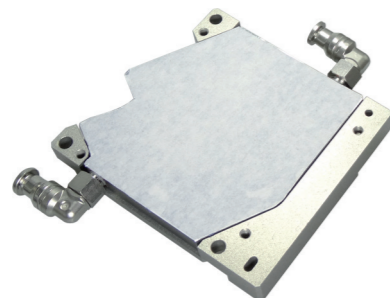

- Remove the protective film from the heat-conductive pad on the left cooling plate and join the left base plate with the left cooling plate to the sensor.

- Join the left base plate with the left cooling plate to the scanner.



- ⓘ Pressing the scanner onto the protective glass slot in order to avoid gap formation ensures proper function of the blow-out system.

- Tighten the fastening screw M5x16 with a torque of 3.5 Nm.

Slightly tighten the adjusting screw on the base plates by hand as far as it will go in order to ensure proper heat dissipation. Screw back by 1/2 turn. The pitch of the adjusting screw is 0.75 mm/turn.

- ⓘ Make sure that the ball bearing is half compressed when installed in order to achieve the optimal tolerance compensation. This is why the adjusting screw must be turned back by 1/2 turn after being slightly tightened to the stop.

- Push the protective glass from the front into the slot as far as it will go.

- Mount the protective plate at the laser entrance window. For fastening, use the Allen screw (M4x8) and the set screw (M4x10) included in the scope of supply.



## Mounting of Protective Housing

- Join the scanner to the left base plate with the protective glass slot.
- Join the right base plate to the scanner.



- ⓘ Pressing the scanner onto the protective glass slot in order to avoid gap formation ensures proper function of the blow-out system.

- Tighten the fastening screw M5x12 with a torque of 3.5 Nm.

- Push the protective glass from the front into the protective glass slot as far as it will go.

- Mount the protective plate at the laser entrance window. For fastening, use the Allen screw (M4x6) and the set screw (M4x6) included in the scope of supply.



## Laser Class Marking

The scanCONTROL 25xx/26xx/29xx sensors operate with a semiconductor laser with a wavelength of 658 nm (visible/red) or 405 nm (visible/blue). The operation of the laser is indicated by an LED on the sensor.

The laser warning signs are concealed by the protective or protective/cooling housings or had been removed prior to mounting. Additional stickers (warning signs etc.) are included in the delivery.

- Stick the signs according to the laser class of your scanner on the protective or protective/cooling housing, front and rear.

## 2M Laser Class

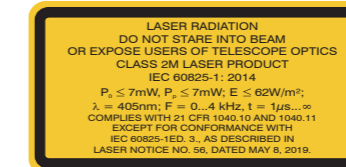

LLT29xx-10/BL

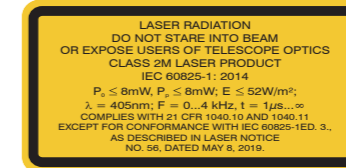

LLT25xx-25/BL, LLT25xx-50/BL,  
LLT25xx-100/BL, LLT29xx-25/BL,  
LLT29xx-50/BL, LLT29xx-100/BL

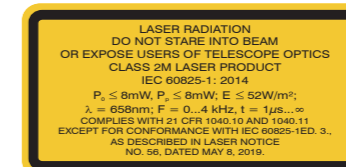

LLT25xx-25, LLT25xx-50,  
LLT25xx-100, LLT26xx-25,  
LLT26xx-50, LLT26xx-100,  
LLT29xx-25, LLT29xx-50,  
LLT29xx-100

## 3B Laser Class

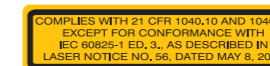
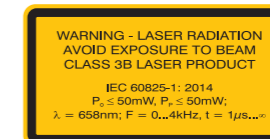

LLT25xx-25, LLT25xx-50,  
LLT25xx-100, LLT26xx-25,  
LLT26xx-50, LLT26xx-100,  
LLT29xx-25, LLT29xx-50,  
LLT29xx-100

